

ATWATER VILLAGE PARKING STUDY AREA
Current Parking

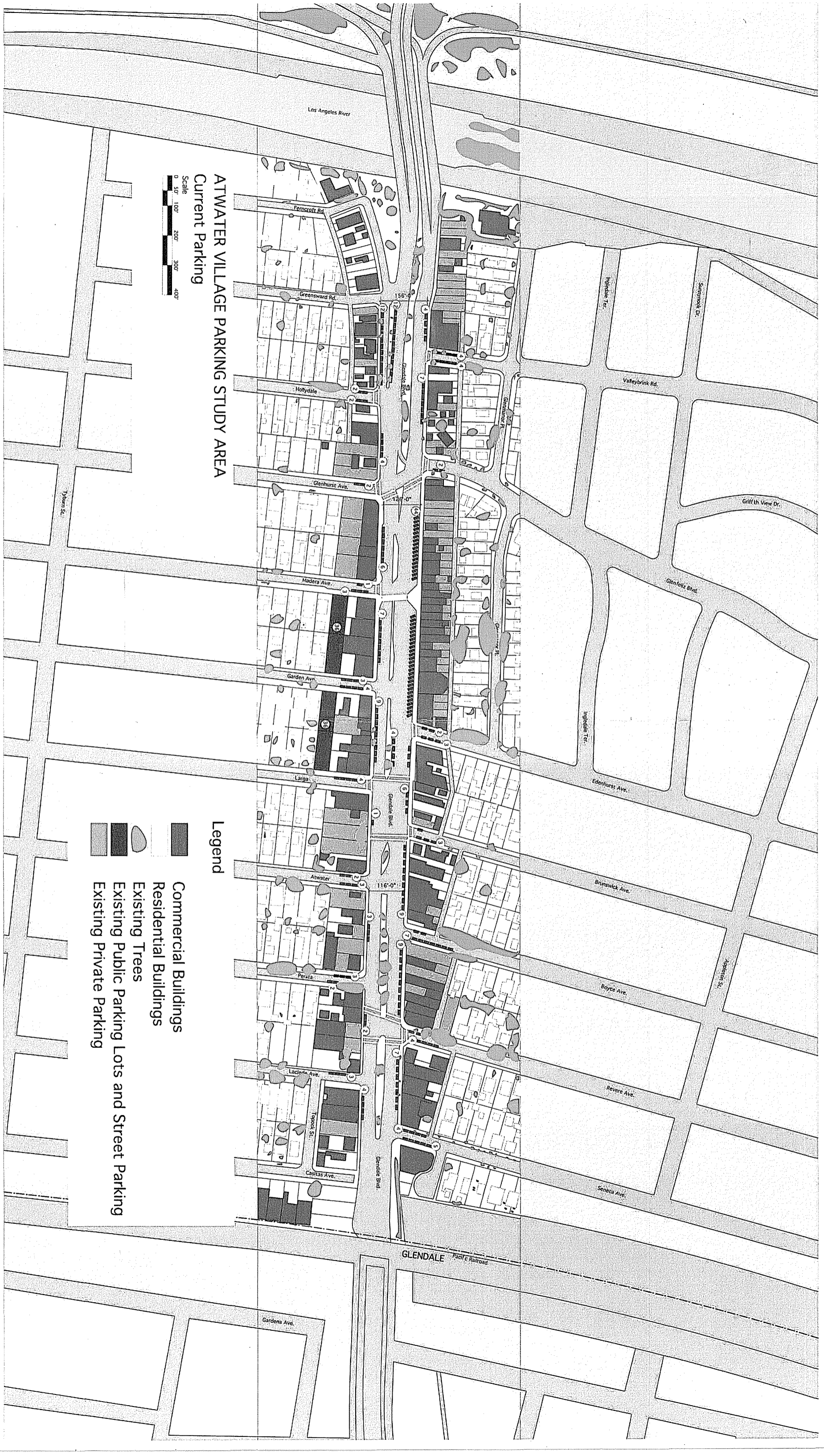

- Legend**
- Commercial Buildings
 - Residential Buildings
 - Existing Trees
 - Existing Public Parking Lots and Street Parking
 - Existing Private Parking



GLENDALE
 Pacific Railroad

Submitted
1/14/09
Comm
09-1

Atwater Village Zoning Parking Credit Progr

January 14, 2009

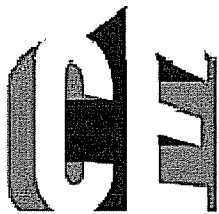

Civic Enterprise Associates LLC

*Submitted in Committee
1/14/09
Communication from CD13
09-0035*

**Atwater Village
Zoning Parking Credit Program
January 14, 2009**

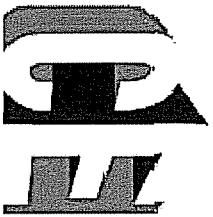

Civic Enterprise Associates LLC

Goals of Program:

- **Move from ad hoc planning to Real Planning**
- **Create a livelier, more walkable and safer Glendale Boulevard**
 - Preserve and enhance pedestrian-oriented street-facing commercial uses
- **Support small neighborhood businesses**
 - Allow reuse of existing structures
 - Reduce cost and time barriers to opening new business

Problem:

Typical existing building and what the neighborhood wants to z:

Typical Existing Building:
7,500 sq. ft., "zero lot line"

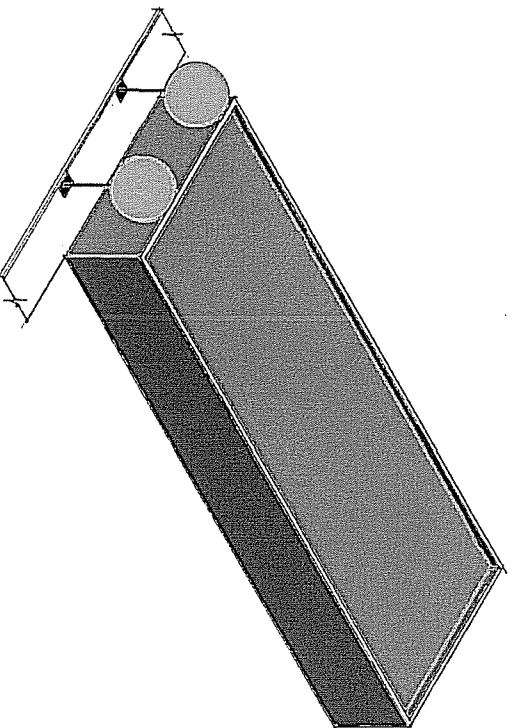

The type of project that can be approved over the counter:

"By-Right" Restaurant Building:
1,665 sq. ft. (improvements)
16 stalls (10 per 1000 ft²)

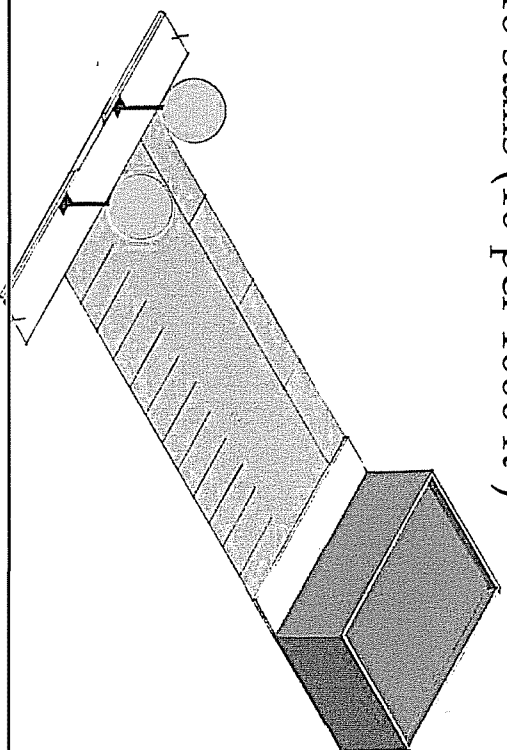

Solution: Zoning Parking Credits

- **Allows for real planning (not ad hoc)**
- **Maximize use of public parking resources**
 - On-street parking adjacent to commercially-zoned properties
 - City-owned parking lots
- **Parking Utilization Survey: June 2008**
 - On average, only 47% of spaces occupied
- **Allow small businesses to satisfy parking requirements by leasing zoning parking credits from City**

How Zoning Parking Credits Help Small Businesses and Neighborhood

Standard Process:

- Open-ended
- 12 – 24 months to permits
- \$50,000 - \$100,000 (est.) in consulting fees
- Kills many small businesses who try
- Piecemeal planning
- Incentivizes auto-oriented development

Zoning Parking Credit Process:

- Predictable
- Over the counter
- Little to no cost for review
- Works best for small businesses
- Allows for comprehensive planning
- Incentivizes pedestrian-oriented development

Atwater Village: Number of Zoning Parking Credits

