

City Hall East
200 N. Main Street
Room 800
Los Angeles, CA 90012

(213) 978-8100 Tel
(213) 978-8312 Fax
CTrutanich@lacity.org
www.lacity.org/atty

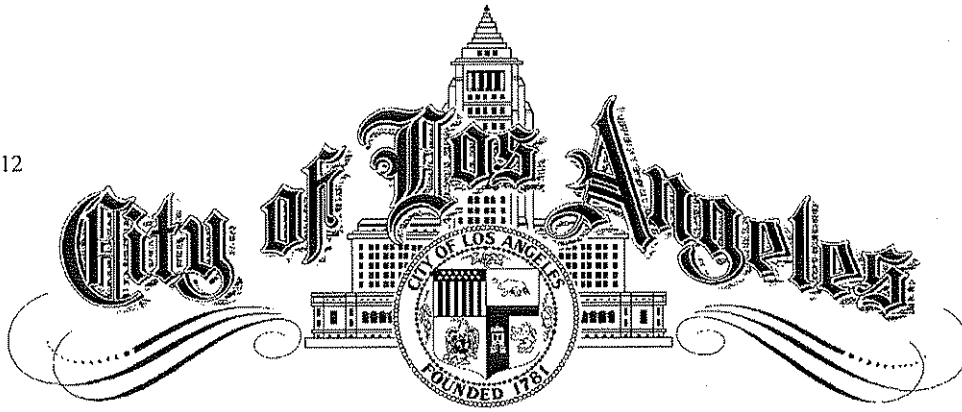

CARMEN A. TRUTANICH
City Attorney

REPORT NO. R 1 1 - 0 1 9 0

REPORT RE:

MAY 2 5 2011

**DRAFT ORDINANCE AMENDING CHAPTER IX OF THE
LOS ANGELES MUNICIPAL CODE TO ESTABLISH
THE LOS ANGELES RESIDENTIAL CODE**

The Honorable City Council
of the City of Los Angeles
Room 395, City Hall
200 North Spring Street
Los Angeles, California 90012

Council File 10-2335

Honorable Members:

We are transmitting to you for your consideration, approved as to form and legality, a draft ordinance incorporating the California Residential Code (CRC) as revised, to establish the Los Angeles Residential Code.

Summary of Ordinance Provisions

When this matter was considered by your Honorable Planning and Land Use Management (PLUM) Committee, the Committee requested that the City Attorney prepare the final ordinance based on the proposed ordinance submitted at the Committee meeting by the Department of Building and Safety (DBS) and attached to the Council file.

The enclosed ordinance incorporates the CRC with modifications, exceptions and additions to reflect local topographical and geological conditions within the Los Angeles/Long Beach region, the possibility of earthquakes and the special needs for buildings constructed on hillside locations.

CEQA Determination

We recommend that, prior to adoption of this ordinance, you determine that your action is exempt from the California Environmental Quality Act ("CEQA") under State CEQA Guidelines sections 15060(c)(2) and (3) because it will not result in a direct, or reasonably foreseeable indirect physical change in the environment as the ordinance establishes design standards for the construction of buildings and structures for enforcement purposes only. In addition, council may determine that adoption of the ordinance is exempt from CEQA under City CEQA Guidelines Article II, Section 1 (General Exemption) because it can be seen with certainty that there is no possibility that the activity in question may have a significant effect on the environment.

If the Council concurs with the above, it may comply with CEQA by making one or all of these determinations prior to or concurrent with its action on the ordinance. It is also recommended that you direct Staff to cause the filing of a Notice of Exemption in accordance with CEQA Guidelines Section 15062.

Council Rule 38 Referral

The draft ordinance was sent, pursuant to Council Rule 38, to the Department of Building and Safety with a request that they provide any comments directly to the City Council or its Committees when the matter is considered.

If you have any questions regarding this matter, please contact Deputy City Attorney Kim Rodgers Westhoff at (213) 978-8242. She or another member of this Office will be present when you consider this matter to answer any questions you may have.

Very truly yours,

CARMEN A. TRUTANICH, City Attorney

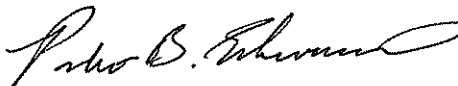
By 
PEDRO B. ECHEVERRIA
Chief Assistant City Attorney

PBE/KRW:pj
Transmittal

ORDINANCE NO. _____

An ordinance amending Chapter IX of the Los Angeles Municipal Code by adding a new Article 1.5 to incorporate by reference various portions of the 2009 International Residential Code (IRC) and the 2010 Edition of the California Residential Code (CRC).

**THE PEOPLE OF THE CITY OF LOS ANGELES
DO ORDAIN AS FOLLOWS:**

Section 1. Chapter IX of the Los Angeles Municipal Code is amended by adding a new Article 1.5, Residential Code, to read as follows:

**ARTICLE 1.5
LOS ANGELES RESIDENTIAL CODE**

ARTICLE 1.5, DIVISION 1

SEC. 91.5.100. BASIC PROVISIONS.

The Los Angeles Residential Code adopts by reference portions of the California Residential Code (CRC). Chapter 1 of the CRC is not adopted. Article 1, Division 1 of Chapter IX of the Los Angeles Municipal Code is adopted by reference.

SEC. 91.5.101. TITLE.

Article 1.5 of Chapter IX of the Los Angeles Municipal Code shall collectively be known as the Los Angeles Residential Code or LARC. The provisions of the LARC for one- and two-family dwellings shall apply to the construction, alteration, movement, enlargement, replacement, repair, equipment, use and occupancy, location, removal and demolition of detached one- and two-family dwellings and townhouses not more than three stories above grade plane in height with a separate means of egress and their accessory structures. In addition to the LARC, Chapters 1, 11A, 11B, 17, 31B, 34, 63, 67, 70, 71, 72, 81, 89, 92, 93 and 96 of the Los Angeles Building Code (LABC) shall also be applicable to one- and two-family dwellings and townhouses unless stated otherwise. Wherever the word Code is used in this Article it shall mean the Los Angeles Building Code.

The Los Angeles Building Code and the Los Angeles Residential Code adopt by reference portions of the California Building Code (CBC) or the California Residential Code (CRC) respectively.

Exception: Live/work units complying with the requirements of Section 419 of the California Building Code shall be permitted to be built as one- and two-family dwellings or townhouses. Fire suppression required by Section 419.5 of the California Building Code when constructed under the California Residential Code for one- and two-

family dwellings shall conform to Section 903.3.1.3 of the California Building Code.

ARTICLE 1.5, DIVISION 2

SEC. 91.5.200. BASIC PROVISIONS.

Chapter 2 of the CRC is hereby adopted by reference with the following exceptions, modifications and additions.

SEC. 91.5.201. GENERAL.

SEC. 91.5.201.4. Terms Not Defined. The definitions in Webster's Third New California Dictionary of the English Language, Unabridged, shall be considered as providing ordinarily accepted meanings.

SEC. 91.5.202. DEFINITIONS.

Section 202 of the CRC is adopted by reference, except that the following CRC definitions are not adopted:

ATTIC, HABITABLE.

BUILDING OFFICIAL.

FAMILY.

LOT.

The following definitions are adopted:

BUILDING OFFICIAL. See Los Angeles Municipal Code Section 91.202.

LOT. See Los Angeles Municipal Code Section 12.03.

SUPERINTENDENT OF BUILDING. See Los Angeles Municipal Code Section 91.202.

ARTICLE 1.5, DIVISION 3

SEC. 91.5.300. BASIC PROVISIONS.

Chapter 3 of the CRC is hereby adopted by reference with the following exceptions, modifications and additions.

SEC. 91.5.301.1.3. Engineered Design. When a building of otherwise conventional construction contains structural elements exceeding the limits of CRC Section R301 or otherwise not conforming to this Code, these elements shall be designed in accordance with accepted engineering practice. The extent of such design need only demonstrate compliance of nonconventional elements with other applicable provisions and shall be compatible with the performance of the conventional framed system. Engineered design in accordance with the Los Angeles Building Code is permitted for all buildings and structures, and parts thereof, included in the scope of this Code.

Buildings with masonry or concrete walls or of light frame construction exceeding two stories shall have an engineered design in accordance with the Los Angeles Building Code.

SEC. 91.5.301.1.3.2. Woodframe Structures. The Building Official shall require construction documents to be approved and stamped by a California licensed architect or engineer for all dwellings of woodframe construction more than two stories and basement in height located in Seismic Design Category A, B, or C. Notwithstanding other provisions of law, the law establishing these provisions is found in Business and Professions Code Sections 5537 and 6737.1.

The Building Official shall require construction documents to be approved and stamped by a California licensed architect or engineer for all dwellings of woodframe construction more than one story in height located in Seismic Design Category D₀, D₁, D₂, or E.

SEC. 91.5.301.1.4. Seismic Design Provisions for Buildings Constructed On Or Into Slopes Steeper Than One Unit Vertical In Three Units Horizontal (33.3 Percent Slope). The design and construction of new buildings and additions to existing buildings when constructed on or into slopes steeper than one unit vertical in three units horizontal (33.3 percent slope) shall comply with Section 91.1613.9 of the Los Angeles Municipal Code.

**TABLE R301.2(1)
CLIMATIC AND GEOGRAPHIC DESIGN CRITERIA**

GROUND SNOW LOAD	WIND DESIGN		SEISMIC DESIGN CATEGORY ^f	SUBJECT TO DAMAGE FROM			WINTER DESIGN TEMP ^g	ICE BARRIER UNDERLAYMENT REQUIRED ^h	FLOOD HAZARDS ⁹	AIR FREEZING INDEX ⁱ	MEAN ANNUAL TEMP ^j
	Speed ^a (mph)	Topographic effects ^k		Weathering ^a	Frost line depth ^b	Termite ^c					
0	85	No	D ₂ /E	Negligible	12"	Yes	39° to 44°	No	See Flood Map	0	61.1°

For SI: 1 pound per square foot = 0.0479 kPa, 1 mile per hour = 0.447 m/s.

- a. Weathering may require a higher strength concrete or grade of masonry than necessary to satisfy the structural requirements of this code. The weathering column shall be filled in with the weathering index (i.e., "negligible," "moderate" or "severe") for concrete as determined from the Weathering Probability Map [Figure R301.2(3)]. The grade of masonry units shall be determined from ASTM C 34, C 55, C 62, C 73, C 90, C 129, C 145, C 216 or C 652.
- b. The frost line depth may require deeper footings than indicated in Figure R403.1(1). The jurisdiction shall fill in the frost line depth column with the minimum depth of footing below finish grade.
- c. The jurisdiction shall fill in this part of the table to indicate the need for protection depending on whether there has been a history of local subterranean termite damage.
- d. The jurisdiction shall fill in this part of the table with the wind speed from the basic wind speed map [Figure R301.2(4)]. Wind exposure category shall be determined on a site-specific basis in accordance with Section R301.2.1.4.
- e. *Temperatures* shall be permitted to reflect local climates or local weather experience as determined by the building official.
- f. The jurisdiction shall fill in this part of the table with the seismic design category determined from Section R301.2.2.1.
- g. The jurisdiction shall fill in this part of the table with (a) the date of the jurisdiction's entry into the National Flood Insurance Program (date of adoption of the first code or ordinance for management of flood hazard areas), (b) the date(s) of the Flood Insurance Study and (c) the panel numbers and dates of all currently effective FIRMs and FBFMs or other flood hazard map adopted by the authority having jurisdiction, as amended.
- h. In accordance with Sections R905.2.7.1, R905.4.3.1, R905.5.3.1, R905.6.3.1, R905.7.3.1 and R905.8.3.1, where there has been a history of local damage from the effects of ice damming, the jurisdiction shall fill in this part of the table with "YES." Otherwise, the jurisdiction shall fill in this part of the table with "NO."
- i. The jurisdiction shall fill in this part of the table with the 100-year return period air freezing index (BF-days) from Figure R403.3(2) or from the 100-year (99%) value on the National Climatic Data Center data table "Air Freezing Index- USA Method (Base 32°)" at www.ncdc.noaa.gov/fpsf.html.
- j. The jurisdiction shall fill in this part of the table with the mean annual temperature from the National Climatic Data Center data table "Air Freezing Index-USA Method (Base 32°F)" at www.ncdc.noaa.gov/fpsf.html.
- k. In accordance with Section R301.2.1.5, where there is local historical data documenting structural damage to buildings due to topographic wind speed-up effects, the jurisdiction shall fill in this part of the table with "YES." Otherwise, the jurisdiction shall indicate "NO" in this part of the table.

SEC. 91.5.301.2.2.2.5. Irregular Buildings. Prescriptive construction as regulated by this code shall not be used for irregular structures located in Seismic Design Categories C, D₀, D₁ and D₂. Irregular portions of structures shall be designed in accordance with accepted engineering practice to the extent the irregular features affect the performance of the remaining structural system. When the forces associated with the irregularity are resisted by a structural system designed in accordance with accepted engineering practice, design of the remainder of the building shall be permitted using the provisions of this code. A building or portion of a building shall be considered to be irregular when one or more of the following conditions occur:

1. When exterior shear wall lines or braced wall panels are not in one plane vertically from the foundation to the uppermost story in which they are required;

2. When a section of floor or roof is not laterally supported by shear walls or braced wall lines on all edges;

Exception: Portions of floors that do not support shear walls or braced wall panels above, or roofs, shall be permitted to extend no more than 6 feet (1829 mm) beyond a shear wall or braced wall line.

3. When the end of a braced wall panel occurs over an opening in the wall below;

4. When an opening in a floor or roof exceeds the lesser of 12 feet (3658 mm) or 50 percent of the least floor or roof dimension;

5. When portions of a floor level are vertically offset;

6. When shear walls and braced wall lines do not occur in two perpendicular directions;

7. When stories above-grade partially or completely braced by wood wall framing in accordance with CBC Section R602 or steel wall framing in accordance with CBC Section R603 include masonry or concrete construction;

Exception: Fireplaces, chimneys and masonry veneer as permitted by this code. When this irregularity applies, the entire story shall be designed in accordance with accepted engineering practice.

SEC. 91.5.301.2.2.3.5.1. AISI S230, Section B1. AISI S230, Section B1 is modified to read as follows:

Where No. 8 screws are specified, the required number of screws in a steel-to-steel connection shall be permitted to be reduced in accordance with the reduction factors in Table B1-1, when larger screws are used or when sheets of steel are being

connected and are thicker than 33 mils (0.84mm). When applying the reduction factor, the resulting number of screws shall be rounded up.

SEC. 91.5.311.2. Egress Door. At least one egress door shall be provided for each dwelling unit. The egress door shall be side-hinged, and shall provide a minimum clear width of 32 inches (813 mm) when measured between the face of the door and the stop, with the door open 90 degrees (1.57 rad). The minimum clear height of the door opening shall not be less than 78 inches (1981 mm) in height measured from the top of the threshold to the bottom of the stop. This is accomplished by providing a door not less than 3 feet in width and 6 feet 8 inches in height. Egress doors shall be readily openable from inside the dwelling without the use of a key or special knowledge or effort. Every interior door in a doorway through which occupants pass shall have a minimum width of 32 inches (813 mm).

SEC. 91.5.322.1.4.1. Determination of Design Flood Elevations. If design flood elevations are not specified, the building official is authorized to require the applicant to:

1. Obtain and reasonably use data available from a federal, state or other source; or
2. Determine the design flood elevation in accordance with accepted hydrologic and hydraulic engineering practices used to define special flood hazard areas. Determinations shall be undertaken by a registered civil engineer who shall document that the technical methods used reflect currently accepted engineering practice. Studies, analyses and computations shall be submitted in sufficient detail to allow thorough review and approval.

ARTICLE 1.5, DIVISION 4

SEC. 91.5.400. BASIC PROVISIONS.

Chapter 4 of the CRC is hereby adopted by reference with the following exceptions, modifications and additions.

SEC. 91.5.401.1. Application. The provisions of this division shall control the design and construction of the foundation and foundation spaces for all buildings. In addition to the provisions of this division, the design and construction of foundations in areas prone to flooding as established by Table R301.2(1) shall meet the provisions of CRC Section R322. Wood foundations shall be designed and installed in accordance with AF&PA PWF.

Exception: The provisions of this Chapter shall be permitted to be used for wood foundations only in the following situations:

1. In buildings that have no more than two floors and a roof;

2. When interior basement and foundation walls are constructed at intervals not exceeding 50 feet (15 240 mm).

Wood foundations in Seismic Design Category D₀, D₁, or D₂ shall not be permitted.

Exception: In non-occupied, single-story, detached storage sheds and similar uses other than carport or garage, provided the gross floor area does not exceed 200 square feet, the plate height does not exceed 12 feet in height above the grade at any point, and the maximum roof projection does not exceed 24 inches.

SEC. 91.5.403.1.2. Continuous Footing in Seismic Design Categories D₀, D₁, and D₂. The braced wall panels at exterior walls of buildings located in Seismic Design Categories D₀, D₁, and D₂ shall be supported by continuous footings. All required interior braced wall panels in buildings shall also be supported by continuous footings.

SEC. 91.5.403.1.3. Seismic Reinforcing. Concrete footings located in Seismic Design Categories D₀, D₁, and D₂, as established in Table R301.2(1), shall have minimum reinforcement. Bottom reinforcement shall be located a minimum of 3 inches (76 mm) clear from the bottom of the footing.

In Seismic Design Categories D₀, D₁, and D₂ where a construction joint is created between a concrete footing and a stem wall, a minimum of one No. 4 bar shall be installed at not more than 4 feet (1219 mm) on center. The vertical bar shall extend to 3 inches (76 mm) clear of the bottom of the footing, have a standard hook and extend a minimum of 14 inches (357 mm) into the stem wall.

In Seismic Design Categories D₀, D₁, and D₂ where a grouted masonry stem wall is supported on a concrete footing and stem wall, a minimum of one No. 4 bar shall be installed at not more than 4 feet (1219 mm) on center. The vertical bar shall extend to 3 inches (76 mm) clear of the bottom of the footing and have a standard hook.

In Seismic Design Categories D₀, D₁, and D₂ masonry stem walls without solid grout and vertical reinforcing are not permitted.

Exception: In detached one- and two-family dwellings located in Seismic Design Category A, B, or C which are three stories or less in height and constructed with stud bearing walls, plain concrete footings without longitudinal reinforcement supporting walls and isolated plain concrete footings supporting columns or pedestals are permitted.

SEC. 91.5.403.1.5. Slope. The top surface of footings shall be level. The bottom surface of footings shall not have a slope exceeding one unit vertical in 10 units horizontal (10-percent slope). Footings shall be stepped where it is necessary to change the elevation of the top surface of the footings or where the slope of the bottom

elevation of the top surface of the footings or where the slope of the bottom surface of the footings will exceed one unit vertical in ten units horizontal (10-percent slope).

For structures located in Seismic Design Categories D₀, D₁, and D₂, or E, stepped footings shall be reinforced with four ½-inch diameter (12.7 mm) deformed reinforcing bars. Two bars shall be placed at the top and bottom of the footing as shown in figure 91.5.403.1.5.

Figure 91.5.403.1.5
STEPPED FOOTING

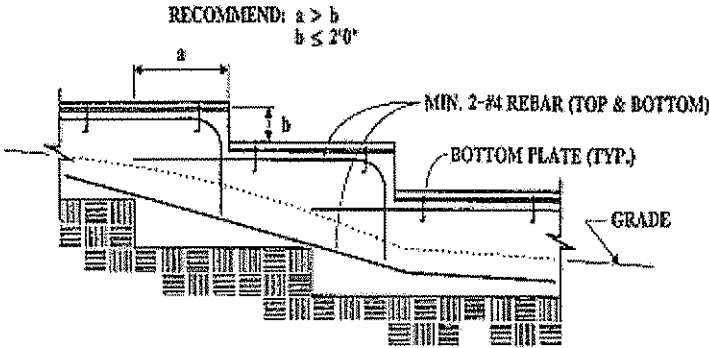

STEPPED FOUNDATIONS

SEC. 91.5.404.2. Wood Foundation Walls. Wood foundation walls shall be constructed in accordance with the provisions of CRC Sections R404.2.1 through R404.2.6 and with the details shown in CRC Figures R403.1(2) and R403.2(3). Wood foundation walls shall not be used for structures located in Seismic Design Category D₀, D₁, or D₂.

ARTICLE 1.5, DIVISION 5

SEC. 91.5.500. BASIC PROVISIONS.

Chapter 5 of the CRC is hereby adopted by reference with the following exceptions, modifications and additions.

SEC. 91.5.501.1. Application. The provision of this Division shall control the design and construction of the floors for all buildings including the floors of attic spaces used to house mechanical or plumbing fixtures and equipment weighing less than 400 lbs and maximum height of 4 feet above the floor or attic level.

SEC. 91.5.503.2.4. Openings in Horizontal Diaphragms. Openings in horizontal diaphragms with a dimension perpendicular to the joist that is greater than 4 feet (1.2 m) shall be constructed in accordance with Figure 91.5.503.2.4.

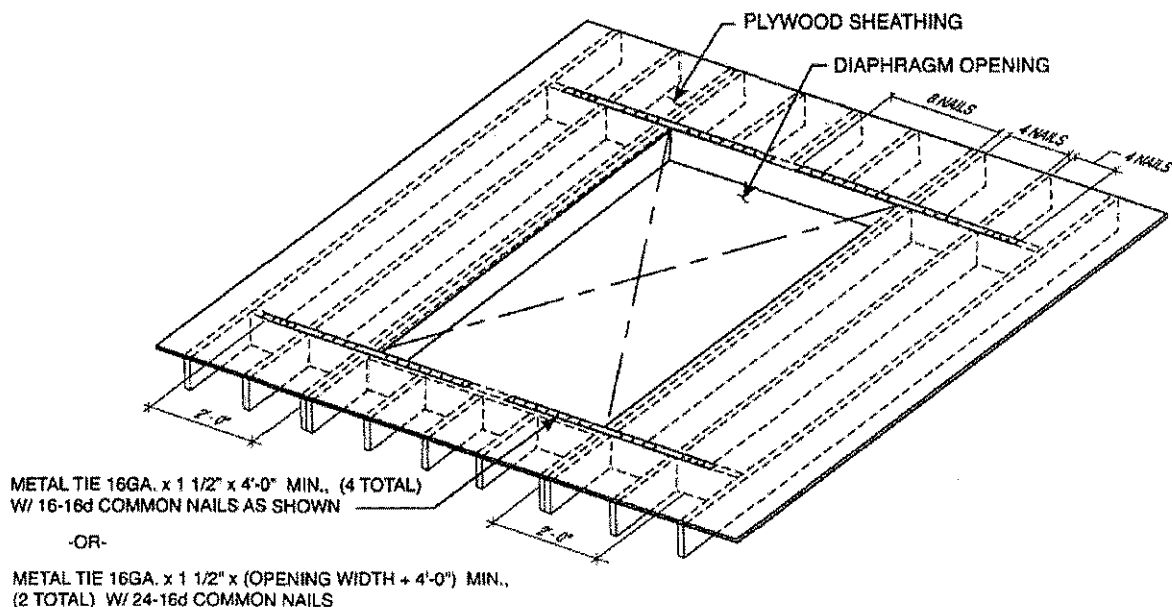

For SI: 1 inch = 25.4 mm, 1 foot = 304.8 mm.

- a. Blockings shall be provided beyond headers.
- b. Metal ties not less than 0.058 inch [1.47 mm (16 galvanized gage)] by 1.5 inches (38 mm) wide with eight 16d common nails on each side of the header-joist intersection. The metal ties shall have a minimum yield of 33,000 psi (227 MPa).
- c. Openings in diaphragms shall be further limited in accordance with Section R301.2.2.2.5.

Figure 91.5.503.2.4

ARTICLE 1.5, DIVISION 6

SEC. 91.5.600. BASIC PROVISIONS.

Chapter 6 of the CRC is hereby adopted by reference with the following exceptions, modifications and additions.

**TABLE 91.5.602.3(1)
FASTENER SCHEDULE FOR STRUCTURAL MEMBERS**

ITEM	DESCRIPTION OF BUILDING ELEMENTS	NUMBER AND TYPE OF FASTENER ^{a, b, c}	SPACING OF FASTENERS
Roof			
1	Blocking between joists or rafters to top plate, toe nail	3-8d (2 1/2" x 0.113")	—
2	Ceiling joists to plate, toe nail	3-8d (2 1/2" x 0.113")	—
3	Ceiling joists not attached to parallel rafter, laps over partitions, face nail	3-10d	—
4	Collar tie rafter, face nail or 1 1/4" 20 gauge ridge strap	3-10d (3" x 0.128")	—
5	Rafter to plate, toe nail	2-16d (3 1/2" x 0.135")	—
6	Roof rafters to ridge, valley or hip rafters: toe nail face nail	4-16d (3 1/2" x 0.135") 3-16d (3 1/2" x 0.135")	— —
Wall			
7	Built-up corner studs	10d (3" x 0.128")	24" o.c.
8	Built-up header, two pieces with 1/2" spacer	16d (3 1/2" x 0.135")	16" o.c. along each edge
9	Continued header, two pieces	16d (3 1/2" x 0.135")	16" o.c. along each edge
10	Continuous header to stud, toe nail	4-8d (2 1/2" x 0.113")	—
11	Double studs, face nail	10d (3" x 0.128")	24" o.c.
12	Double top plates, face nail	10d (3" x 0.128")	24" o.c.
13	Double top plates, minimum 48-inch offset of end joints, face nail in lapped area	8-16d (3 1/2" x 0.135")	—
14	Sole plate to joist or blocking, face nail	16d (3 1/2" x 0.135")	16" o.c.
15	Sole plate to joist or blocking at braced wall panels	3-16d (3 1/2" x 0.135")	16" o.c.
16	Stud to sole plate, toe nail	3-8d (2 1/2" x 0.113") or 2-16d (3 1/2" x 0.135")	— —
17	Top or sole plate to stud, end nail	2-16d (3 1/2" x 0.135")	—
18	Top plates, laps at corners and intersections, face nail	2-10d (3" x 0.128")	—
19	1" brace to each stud and plate, face nail	2-8d (2 1/2" x 0.113") 2 staples 1 3/4"	— —
20	1" x 6" sheathing to each bearing, face nail	2-8d (2 1/2" x 0.113") 2 staples 1 3/4"	— —
21	1" x 8" sheathing to each bearing, face nail	2-8d (2 1/2" x 0.113") 3 staples 1 3/4"	— —
22	Wider than 1" x 8" sheathing to each bearing, face nail	3-8d (2 1/2" x 0.113") 4 staples 1 3/4"	— —

(continued)

Floor				
23	Joist to sill or girder, toe nail	3-8d (2 1/2" x 0.113")	—	
24	1" x 6" subfloor or less to each joist, face nail	2-8d (2 1/2" x 0.113") 2 staples 1 3/4"	—	
25	2" subfloor to joist or girder, blind and face nail	2-16d (3 1/2" x 0.135")	—	
26	Rim joist to top plate, toe nail (roof applications also)	8d (2 1/2" x 0.113")	6" o.c.	
27	2" planks (plank & beam – floor & roof)	2-16d (3 1/2" x 0.135")	at each bearing	
28	Built-up girders and beams, 2-inch lumber layers	10d (3" x 0.128")	Nail each layer as follows: 32" o.c. at top and bottom and staggered. Two nails at ends and at each splice.	
29	Ledger strip supporting joists or rafters	3-16d (3 1/2" x 0.135")	At each joist or rafter	
ITEM	DESCRIPTION OF BUILDING MATERIALS	DESCRIPTION OF FASTENER ^{b, c, e}	SPACING OF FASTENERS	
			Edges (inches) ^l	Intermediate Supports ^{c, e} (inches)
Wood structural panels, subfloor, roof and interior wall sheathing to framing and particleboard wall sheathing to framing				
30	3/8" – 1/2"	6d common (2" x 0.113") nail (subfloor wall) ⁱ 8d common (2 1/2" x 0.131") nail (roof)	6	12 ^g
31	5/16" – 1/2"	6d common (2" x 0.113") nail (subfloor wall) 8d common (2 1/2" x 0.131") nail (roof) ^f	6	12 ^g
32	9/16" – 1"	8d common (2 1/2" x 0.131")	6	12 ^g
33	1 1/8" – 1 1/4"	10d common (3" x 0.148") or 8d common (2 1/2" x 0.131") deformed nail	6	12
Other wall sheathing^h				
34	1/2 structural cellulosic fiberboard sheathing	1/2" galvanized roofing nail,	3	6
35	25/32 structural cellulosic fiberboard sheathing	1 3/4" galvanized roofing nail,	3	6
36	1/2" gypsum sheathing ^d	1 1/2" galvanized roofing nail; 1 1/4" screws, Type W or S	7	7
37	5/8" gypsum sheathing ^d	1 3/4" galvanized roofing nail; 1 5/8" screws, Type W or S	7	7
Wood structural panels, combination subfloor underlayment to framing				
38	3/4" and less	6d deformed (2" x 0.120") nail or 8d common (2 1/2" x 0.131") nail	6	12
39	7/8" – 1"	8d common (2 1/2" x 0.131") nail or 8d deformed (2 1/2" x 0.120") nail	6	12
40	1 1/8" – 1 1/4"	10d common (3" x 0.148") nail or 8d deformed (2 1/2" x 0.120") nail	6	12

For SI: 1 inch = 25.4 mm, 1 foot = 304.8 mm, 1 mile per hour = 0.447 m/s; 1ksi = 6.895 MPa.

- All nails are smooth-common, box or deformed shanks except where otherwise stated. Nails used for framing and sheathing connections shall have minimum average bending yield strengths as shown: 80 ksi for shank diameter of 0.192 inch (20d common nail), 90 ksi for shank diameters larger than 0.142 inch but not larger than 0.177 inch, and 100 ksi for shank diameters of 0.142 inch or less.
- Staples are 16 gauge wire and have a minimum 7/16-inch on diameter crown width.
- Nails shall be spaced at not more than 6 inches on center at all supports where spans are 48 inches or greater.
- 4-foot-by-8-foot or 4-foot-by-9-foot panels shall be applied vertically.
- Spacing of fasteners not included in this table shall be based on Table 91.5.602.3(2).
- For regions having basic wind speed of 110 mph or greater, 8d deformed (2 1/2" x 0.120") nails shall be used for attaching plywood and wood structural panel roof sheathing to framing within minimum 48-inch distance from gable end walls, if mean roof height is more than 25 feet, up to 35 feet maximum.
- For regions having basic wind speed of 100 mph or less, nails for attaching wood structural panel roof sheathing to gable endwall framing shall be spaced 6 inches on center. When basic wind speed is greater than 100 mph, nails for attaching panel roof sheathing to intermediate supports shall be spaced 6 inches on center for minimum 48-inch distance from ridges, eaves and gable end walls; and 4 inches on center to gable end wall framing.
- Gypsum sheathing shall conform to ASTM C 1396 and shall be installed in accordance with GA 253. Fiberboard sheathing shall conform to ASTM C 208.

i. Spacing of fasteners on floor sheathing panel edges applies to panel edges supported by framing members and required blocking and at all floor perimeters only. Spacing of fasteners on roof sheathing panel edges applies to panel edges supported by framing members and required blocking. Blocking of roof or floor sheathing panel edges perpendicular to the framing members need not be provided except as required by other provisions of this code. Floor perimeter shall be supported by framing members or solid blocking.

**TABLE 91.5.602.3(2)
ALTERNATE ATTACHMENTS**

NOMINAL MATERIAL THICKNESS (inches)	DESCRIPTION ^{a, b} OF FASTENER AND LENGTH (inches)	SPACING ^c OF FASTENERS	
		Edges (inches)	Intermediate supports (inches)
Wood structural panels subfloor, roof and wall sheathing to framing and particleboard wall sheathing to framing^f			
Up to 1/2	0.097 – 0.099 Nail 2 1/4	3	6
19/32 and 5/8	0.113 Nail 2	3	6
	0.097 – 0.099 Nail 2 1/4	4	8
23/32 and 3/4	0.097 – 0.099 Nail 2 1/4	4	8
1	0.113 Nail 2 1/4	3	6
	0.097 - 0.099 Nail 2 1/2	4	8
NOMINAL MATERIAL THICKNESS (inches)	DESCRIPTION ^{a, b} OF FASTENER AND LENGTH (inches)	SPACING ^c OF FASTENERS	
		Edges (inches)	Body of panel (inches)
Floor underlayment; plywood-hardboard-particleboard^f			
Plywood			
1/4 and 5/16	1 1/4 ring or screw shank nail—minimum 12 1/2 ga. (0.099") shank diameter	3	6
11/32, 3/8, 15/32, and 1/2	1 1/4 ring or screw shank nail—minimum 12 1/2 ga. (0.099") shank diameter	6	8°
19/32, 5/8, 23/32, 3/4	1 1/2 ring or screw shank nail—minimum 12 1/2 ga. (0.099") shank diameter	6	8
Hardboard^f			
0.200	1 1/2 long ring-grooved underlayment nail	6	6
	4d cement-coated sinker nail	6	6
	Staple 18 ga., 7/8 long (plastic coated)	3	6







(continued)

Particleboard			
1/4	4d ring-grooved underlayment nail	3	6
	Staple 18 ga., 7/8 long, 3/16 crown	3	6
3/8	6d ring-grooved underlayment nail	6	10
	Staple 16 ga., 1 1/8 long, 3/8 crown	3	6
1/2, 5/8	6d ring-grooved underlayment nail	6	10
	Staple 16 ga., 1 5/8 long, 3/8 crown	3	6

For SI: 1 inch = 25.4 mm.



- a. Nail is a general description and may be T-head, modified round head or round head.
- b. Staples shall have a minimum crown width of 7/16 inch on diameter except as noted.
- c. Nails or staples shall be spaced at not more than 6 inches on center at all supports where spans are 48 inches or greater. Nails or staples shall be spaced at not more than 12 inches on center at intermediate supports for floors.
- d. Fasteners shall be placed in a grid pattern throughout the body of the panel.
- e. For 5-ply panels, intermediate nails shall be spaced not more than 12 inches on center each way.
- f. Hardboard underlayment shall conform to ANSI/AHA A135.4.

TABLE 91.5.602.10.1.2(2)^{a, b, c}
BRACING REQUIREMENTS BASED ON SEISMIC DESIGN CATEGORY
(AS A FUNCTION OF BRACED WALL LINE LENGTH)

SOIL CLASS D ^a WALL HEIGHT = 10 FT 10 PSF FLOOR DEAD LOAD 15 PSF ROOF/CEILING DEAD LOAD BRACED WALL LINE SPACING ≤25 FT			MINIMUM TOTAL LENGTH (feet) OF BRACED WALL PANELS REQUIRED ALONG EACH BRACED WALL LINE			
Seismic Design Category (SDC)	Story Location	Braced Wall Line Length	Method LIB	Methods ^d DWB, SFB, GB, PBS, PCP, HPS	Method WSP	Continuous Sheathing
SDC A and B and Detached Dwellings in C						
SDC C		10	2.5	2.5	1.6	1.4
		20	5.0	5.0	3.2	2.7
		30	7.5	7.5	4.8	4.1
		40	10.0	10.0	6.4	5.4
		50	12.5	12.5	8.0	6.8
		10	NP	4.5	3.0	2.6
		20	NP	9.0	6.0	5.1
		30	NP	13.5	9.0	7.7
		40	NP	18.0	12.0	10.2
		50	NP	22.5	15.0	12.8
		10	NP	6.0	4.5	3.8
		20	NP	12.0	9.0	7.7
		30	NP	18.0	13.5	11.5
		40	NP	24.0	18.0	15.3
		50	NP	30.0	22.5	19.1
SDC D ₀ , D ₁		10	NP	6.0	2.0	1.7
		20	NP	12.0	4.0	3.4
		30	NP	18.0	6.0	5.1
		40	NP	24.0	8.0	6.8
		50	NP	30.0	10.0	8.5
		10	NP	NP	4.5	3.8
		20	NP	NP	9.0	7.7
		30	NP	NP	13.5	11.5
		40	NP	NP	18.0	15.3
		50	NP	NP	22.5	19.1
		10	NP	NP	6.0	5.1
		20	NP	NP	12.0	10.2
		30	NP	NP	18.0	15.3
		40	NP	NP	24.0	20.4
		50	NP	NP	30.0	25.5

(continued)

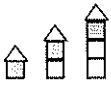
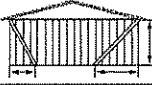

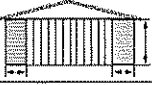
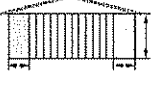
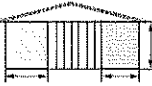

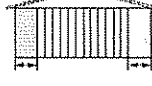



TABLE 91.5.602.10.1.2(2)^{a, b, c}—continued
BRACING REQUIREMENTS BASED ON SEISMIC DESIGN CATEGORY
(AS A FUNCTION OF BRACED WALL LINE LENGTH)

SOIL CLASS D ^a WALL HEIGHT = 10 FT 10 PSF FLOOR DEAD LOAD 15 PSF ROOF/CEILING DEAD LOAD BRACED WALL LINE SPACING ≤25 FT			MINIMUM TOTAL LENGTH (feet) OF BRACED WALL PANELS REQUIRED ALONG EACH BRACED WALL LINE			
Seismic Design Category (SDC)	Story Location	Braced Wall Line Length	Method LIB	Methods ^d DWB, SFB, GB, PBS, PCP, HPS	Method WSP	Continuous Sheathing
SDC D ₂		10	NP	8.0	2.5	2.1
		20	NP	16.0	5.0	4.3
		30	NP	24.0	7.5	6.4
		40	NP	32.0	10.0	8.5
		50	NP	40.0	12.5	10.6
		10	NP	NP	5.5	4.7
		20	NP	NP	11.0	9.4
		30	NP	NP	16.5	14.0
		40	NP	NP	22.0	18.7
		50	NP	NP	27.5	23.4
		10	NP	NP	NP	NP
		20	NP	NP	NP	NP
		30	NP	NP	NP	NP
		40	NP	NP	NP	NP
		50	NP	NP	NP	NP

For SI: 1 foot = 304.8 mm, 1 pound per square foot = 47.89 Pa.

- Wall bracing lengths are based on a soil site class "D." Interpolation of bracing length between the S_{ds} values associated with the seismic design categories shall be permitted when a site-specific S_{ds} value is determined in accordance with Section 1613.5 of the International Building Code.
- Foundation cripple wall panels shall be braced in accordance with Section R602.10.9.
- Methods of bracing shall be as described in Sections R602.10.2, R602.10.4 and R602.10.5.
- Methods GB and PCP braced wall panel h/w ratio shall not exceed 1:1 in SDC D₀, D₁, and D₂.
Methods DWB, SFB, PBS, and HPS are not permitted in SDC D₀, D₁, and D₂.

**TABLE 91.5.602.10.2
INTERMITTENT BRACING METHODS ^a**

METHOD	MATERIAL	MINIMUM THICKNESS	FIGURE	CONNECTION CRITERIA
LIB	Let-in-bracing	1 x 4 wood or approved metal straps at 45° to 60° angles for maximum 16" stud spacing		Wood: 2-8d nails per stud including top and bottom plate metal: per manufacturer
DWB	Diagonal wood boards	¾" (1" nominal) for maximum 24" stud spacing		2-8d (2 ½" x 0.113") nails or 2 staples, 1 ¾ per stud
WSP	Wood structural panel (see Section R604)	15/32"		8d common (2 ½" x 0.131) nails at 6" spacing (panel edge) at 12" spacing (intermediate supports), 3/8" edge distance to panel edge
SFB	Structural fiberboard sheathing	½" or 25/32" for maximum 16" stud spacing		1 ½" galvanized roofing nails or 8d common (2 ½" x 0.131) nails at 3" spacing (panel edges) at 6" spacing (intermediate supports)
GB	Gypsum board	½"		Nails or screws at 7" spacing at panel edges including top and bottom plates; for all braced wall panel locations for exterior sheathing nail or screw size, see Table R602.3(1); for interior gypsum board nail or screw size, see Table R702.3.5
PBS	Particleboard sheathing (see Section R605)	3/8" or ½" for maximum 16" stud spacing		1 1/2" galvanized roofing nails or 8d common (2 1/2" x 0.131) nails at 3" spacing (panel edges) at 6" spacing (intermediate supports)
PCP	Portland cement plaster	See Section R703.6 For maximum 16" stud spacing		1 ½", 11 gage, 7/16" head nails at 6" spacing
HPS	Hardboard panel siding	7/16" For maximum 16" stud spacing		0.092" dia., 0.225" head nails with length to accommodate 11/2" penetration into studs at 4" spacing (panel edges), at 8" spacing (intermediate supports)
ABW	Alternate braced wall	See Section R602.10.3.2		See Section R602.10.3.2
PFH	Intermittent portal frame	See Section R602.10.3.3		See Section R602.10.3.3
PFG	Intermittent portal frame at garage	See Section R602.10.3.4		See Section R602.10.3.4

a. Methods GB and PCP braced wall panel h/w ratio shall not exceed 1:1 in SDC D₀, D₁, and D₂. Methods LIB, DWB, SFB, PBS, HPS, and PFG are not permitted in SDC D₀, D₁, and D₂.

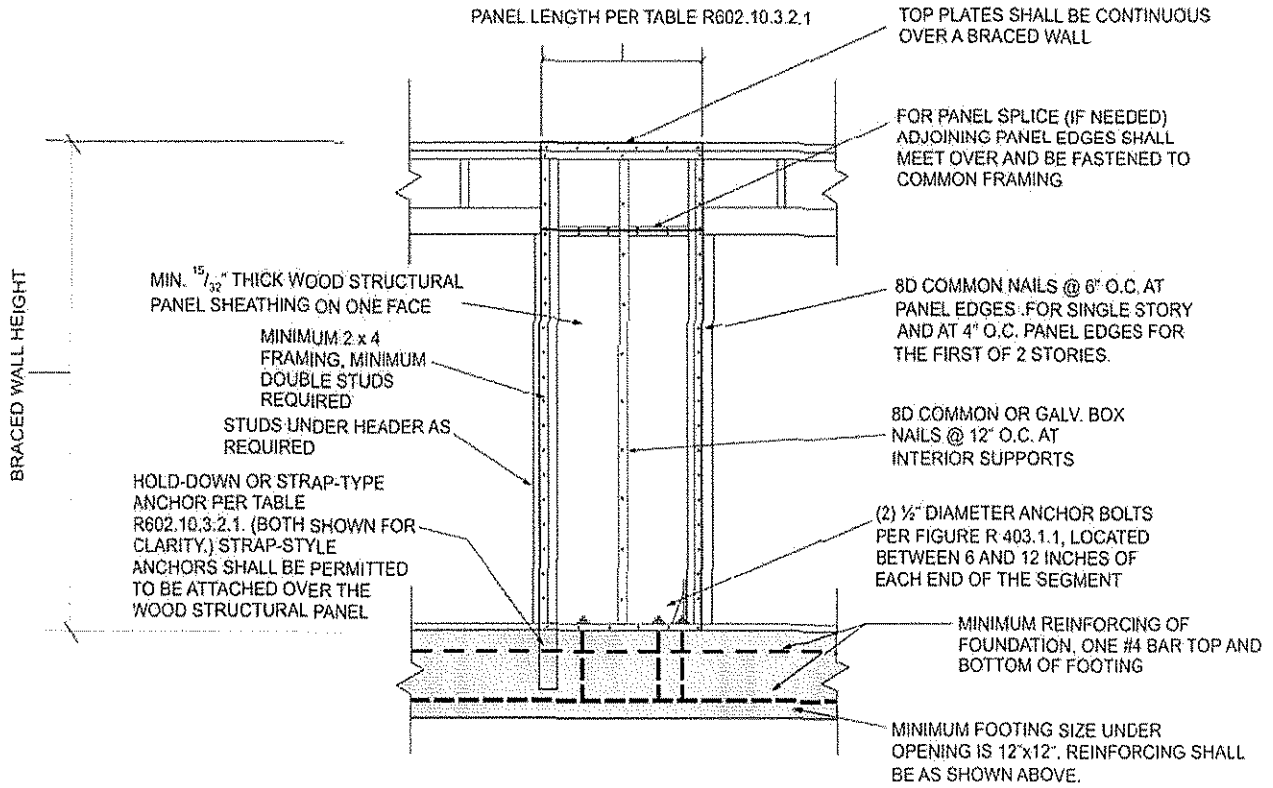

Figure 91.5.602.10.3.2
ALTERNATE BRACED WALL PANEL

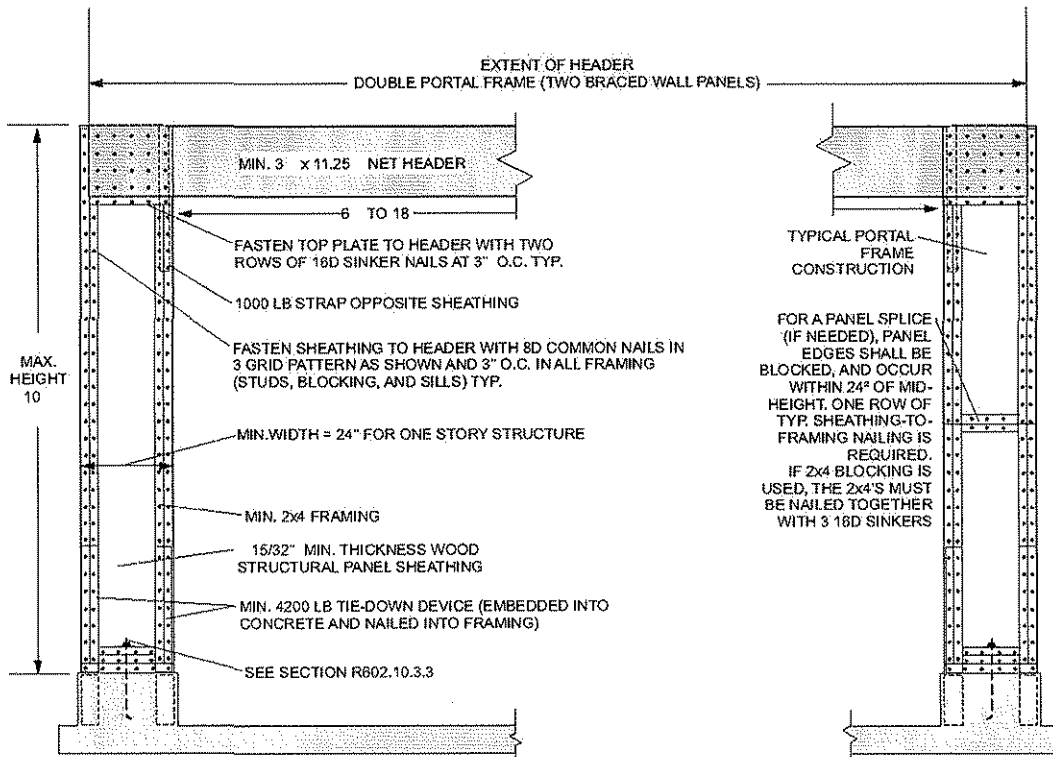

Figure 91.5.602.10.3.3
METHOD PFH: PORTAL FRAME WITH HOLD-DOWNS AT DETACHED GARAGE DOOR OPENINGS.

SEC. 91.5.602.10.3.3. Method PFH: Portal Frame with Hold-Downs. Method PFH braced wall panels constructed in accordance with one of the following provisions are also permitted to replace each 4 feet (1219 mm) of braced wall panel as required by Section 91.5.602.10.3 for use adjacent to a window or door opening with a full-length header:

1. Each panel shall be fabricated in accordance with Figure 91.5.602.10.3.3. The wood structural panel sheathing shall extend up over the solid sawn or glued-laminated header and shall be nailed in accordance with Figure 91.5.602.10.3.3. A spacer, if used with a built-up header, shall be placed on the side of the built-up beam opposite the wood structural panel sheathing. The header shall extend between the inside faces of the first full-length outer studs of each panel. One anchor bolt not less than 5/8-inch-diameter (16 mm) and installed in accordance with CRC Section R403.1.6 shall be provided in the center of each sill plate. The hold-down devices shall be an embedded-strap type, installed in accordance with the manufacturer's recommendations. The panels shall be supported directly on a foundation which is continuous across the entire length of the braced wall line. The foundation shall be reinforced as shown on Figure 91.5.602.10.3.2. This reinforcement shall be lapped not less than 24 inches (610 mm) with the reinforcement required in the continuous foundation located directly under the braced wall line.

2. In the first story of two-story buildings, each wall panel shall be braced in accordance with item 1 above, except that each panel shall have a length of not less than 24 inches (610 mm).

**TABLE 91.5.602.10.4.1
CONTINUOUS SHEATHING METHODS**

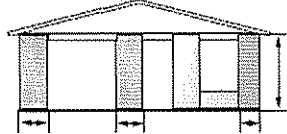
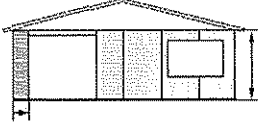
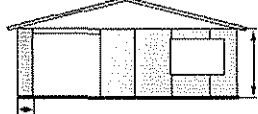
METHOD	MATERIAL	MINIMUM THICKNESS	FIGURE	CONNECTION CRITERIA
CS-WSP	Wood structural panel	15/32"		8d common (2" x 0.113") nails at 6" spacing (panel edges) and at 12" spacing (intermediate supports)
CS-G	Wood structural panel adjacent to garage openings and supporting roof load only ^{a, b}	15/32"		See method CS-WSP
CS-PF	Continuous portal frame	See Section R602.10.4.1		See Section R602.10.4.1

For SI: 1 inch = 25.4 mm, 1 pound per square foot = 47.89 Pa.

a. Applies to one wall of a garage only.

b. Roof covering dead loads shall be 3 psf or less.

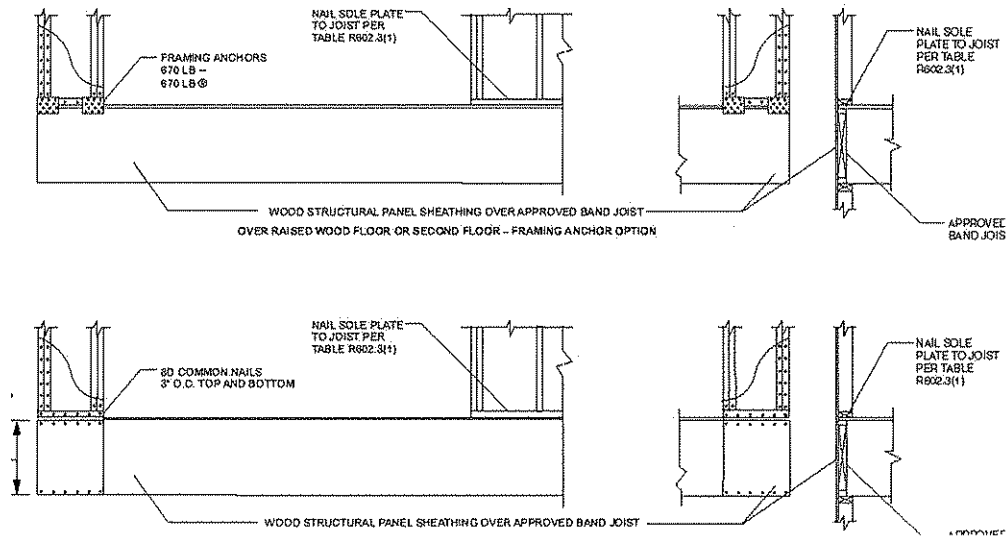
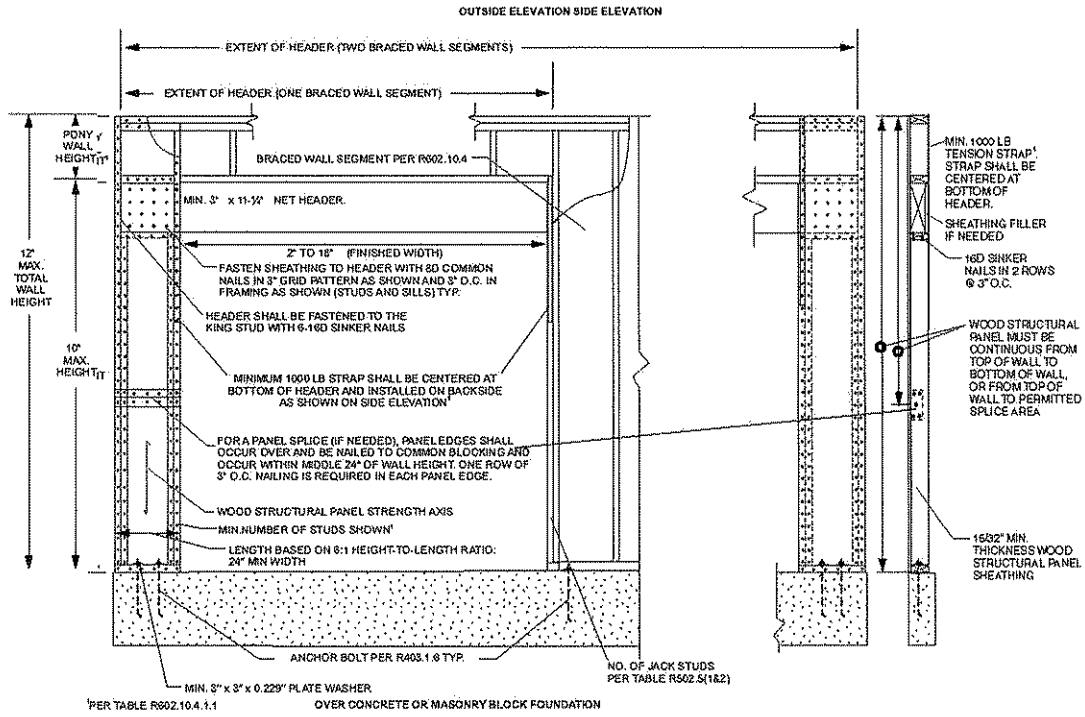

For SI: 1 inch = 25.4 mm, 1 foot = 304.8 mm, 1 pound force = 4.448 N.

Figure 91.5.602.10.4.1.1
METHOD CS-PF: CONTINUOUS PORTAL FRAME PANEL CONSTRUCTION

SEC. 91.5.603.2.4. Fastening Requirements. Screws for steel-to-steel connections shall be installed with a minimum edge distance and center-to-center spacing of 1/2 inch (12.7 mm), shall be self-drilling tapping and shall conform to ASTM C 1513. Structural sheathing shall be attached to cold-formed steel studs with minimum No. 8 self-drilling tapping screws that conform to ASTM C 1513. Screws for attaching structural sheathing to cold-formed steel wall framing shall have a minimum head diameter of 0.292 inch (7.4 mm) with countersunk heads and shall be installed with a minimum edge distance of 3/8 inch (9.5 mm). Gypsum board shall be attached to cold-formed steel wall framing with minimum No. 6 screws conforming to ASTM C 954 or ASTM C 1513 with a bugle head style and shall be installed in accordance with CRC Section R702. For all connections, screws shall extend through the steel a minimum of three exposed threads. All fasteners shall have rust inhibitive coating suitable for the installation in which they are being used, or be manufactured from material not susceptible to corrosion.

Where No. 8 screws are specified in a steel-to-steel connection, the required number of screws in the connection is permitted to be reduced in accordance with the reduction factors in Table R603.2.4, when larger screws are used or when the sheets of steel being connected is thicker than 33 mils (0.84mm). When applying the reduction factor, the resulting number of screws shall be rounded up.

SEC. 91.5.606.2.4. Parapet Walls. Unreinforced solid masonry parapet walls shall not be less than 8 inches (203 mm) thick and their height shall not exceed four times their thickness. Unreinforced hollow unit masonry parapet walls shall be not less than 8 inches (203 mm) thick, and their height shall not exceed three times their thickness. Masonry parapet walls in areas subject to wind loads of 30 pounds per square foot (1.44 kPa) or located in Seismic Design Category D₀, D₁ or D₂, or on townhouses in Seismic Design Category C shall be reinforced in accordance with Section R606.12.

SEC. 91.5.606.12.2.2.3. Reinforcement of Requirements for Masonry Elements. Masonry elements listed in Section R606.12.2.2.2 shall be reinforced in either the horizontal or vertical direction as shown in Figure R606.11(3) and in accordance with the following:

1. Horizontal reinforcement. Horizontal joint reinforcement shall consist of at least one No. 4 bar spaced not more than 48 inches (1219 mm). Horizontal reinforcement shall be provided within 16 inches (406 mm) of the top and bottom of these masonry elements.

2. Vertical reinforcement. Vertical reinforcement shall consist of at least one No. 4 bar spaced not more than 48 inches (1219 mm). Vertical reinforcement shall be within 16 inches (406mm) of the ends of masonry walls.

ARTICLE 1.5, DIVISION 7

SEC. 91.5.700. BASIC PROVISIONS.

Chapter 7 of the CRC is hereby adopted by reference.

ARTICLE 1.5, DIVISION 8

SEC. 91.5.800. BASIC PROVISIONS.

Chapter 8 of the CRC is hereby adopted by reference with the following exceptions, modifications and additions.

TABLE 91.5.802.5.1(9)

RAFTER/CEILING JOIST HEEL JOINT CONNECTIONS^{a, b, c, d, e, f, h}

RAFTER SLOPE	RAFTER SPACING (inches)	GROUND SNOW LOAD (psf)															
		20 ^a				30				50				70			
		Roof span (feet)															
		12	20	28	36	12	20	28	36	12	20	28	36	12	20	28	36
Required number of 16d common nails ^{a, b} per heel joint splices ^{c, d, e, f}																	
3:12	12	4	6	8	10	4	6	8	11	5	8	12	15	6	11	15	20
	16	5	8	10	13	5	8	11	14	6	11	15	20	8	14	20	26
	24	7	11	15	19	7	11	16	21	9	16	23	30	12	21	30	39
4:12	12	3	5	6	8	3	5	6	8	4	6	9	11	5	8	12	15
	16	4	6	8	10	4	6	8	11	5	8	12	15	6	11	15	20
	24	5	8	12	15	5	9	12	16	7	12	17	22	9	16	23	29
5:12	12	3	4	5	6	3	4	5	7	3	5	7	9	4	7	9	12
	16	3	5	6	8	3	5	7	9	4	7	9	12	5	9	12	16
	24	4	7	9	12	4	7	10	13	6	10	14	18	7	13	18	23
7:12	12	3	4	4	5	3	3	4	5	3	4	5	7	3	5	7	9
	16	3	4	5	6	3	4	5	6	3	5	7	9	4	6	9	11
	24	3	5	7	9	3	5	7	9	4	7	10	13	5	9	13	17
9:12	12	3	3	4	4	3	3	3	4	3	3	4	5	3	4	5	7
	16	3	4	4	5	3	3	4	5	3	4	5	7	3	5	7	9
	24	3	4	6	7	3	4	6	7	3	6	8	10	4	7	10	13
12:12	12	3	3	3	3	3	3	3	3	3	3	3	4	3	3	4	5
	16	3	3	4	4	3	3	3	4	3	3	4	5	3	4	5	7
	24	3	4	4	5	3	3	4	6	3	4	6	8	3	6	8	10

For SI: 1 inch = 25.4 mm, 1 foot = 304.8 mm, 1 pound per square foot = 0.0479 kPa.

- a. 40d box nails shall be permitted to be substituted for 16d common nails.
- b. Nailing requirements shall be permitted to be reduced 25 percent if nails are clinched.
- c. Heel joint connections are not required when the ridge is supported by a load-bearing wall, header or ridge beam.
- d. When intermediate support of the rafter is provided by vertical struts or purlins to a loadbearing wall, the tabulated heel joint connection requirements shall be permitted to be reduced proportionally to the reduction in span.
- e. Equivalent nailing patterns are required for ceiling joist to ceiling joist lap splices.
- f. When rafter ties are substituted for ceiling joists, the heel joint connection requirement shall be taken as the tabulated heel joint connection requirement for two-thirds of the actual rafter-slope.
- g. Applies to roof live load of 20 psf or less.
- h. Tabulated heel joint connection requirements assume that ceiling joists or rafter ties are located at the bottom of the attic space. When ceiling joists or rafter ties are located higher in the attic, heel joint connection requirements shall be increased by the following factors:

H_C/H_R	Heel Joint Connection Adjustment Factor
1/3	1.5
1/4	1.33
1/5	1.25
1/6	1.2
1/10 or less	1.11

where:

H_C = Height of ceiling joists or rafter ties measured vertically above the top of the rafter support walls.

H_R = Height of roof ridge measured vertically above the top of the rafter support walls.

SEC. 91.5.802.8. Lateral Support. Roof framing members and ceiling joists having a depth-to-thickness ratio exceeding 2 to 1 based on nominal dimensions shall be provided with lateral support at points of bearing to prevent rotation. For roof rafters with ceiling joists attached per Table R602.3(1), the depth-thickness ratio for the total assembly shall be determined using the combined thickness of the rafter plus the attached ceiling joist.

SEC. 91.5.802.10.2. Design. Wood trusses shall be designed in accordance with accepted engineering practice. The design and manufacture of metal-plate-connected wood trusses shall comply with ANSI/TPI 1. The truss design drawings shall be prepared by a registered professional.

SEC. 91.5.803.2.4. Openings in Horizontal Diaphragms. Openings in horizontal diaphragms shall conform to Section 91.R503.2.4.

ARTICLE 1.5, DIVISION 9

SEC. 91.5.900. BASIC PROVISIONS.

Chapter 9 of the CRC is hereby adopted by reference.

ARTICLE 1.5, DIVISION 10

SEC. 91.5.1000. BASIC PROVISIONS.

Chapter 10 of the CRC is hereby adopted by reference with the following exceptions, modifications and additions.

SEC. 91.5.1001.3.1. Vertical Reinforcing. For chimneys up to 40 inches (1016 mm) wide, four No. 4 continuous vertical bars adequately anchored into the concrete foundation shall be placed between wythes of solid masonry or within the cells of hollow unit masonry and grouted in accordance with Section R609. Grout shall be prevented from bonding with the flue liner so that the flue liner is free to move with thermal expansion. For chimneys more than 40 inches (1016 mm) wide, two additional No. 4 vertical bars adequately anchored into the concrete foundation shall be provided for each additional flue incorporated into the chimney or for each additional 40 inches (1016 mm) in width or fraction thereof.

Sec. 2. Urgency Clause. The City Council finds and declares that this Ordinance is required for the immediate protection of the public peace, health and safety for the following reason: In order for the City of Los Angeles to facilitate a seamless transition with the State of California and its Residential Code and maintain predictability and streamlined case processing for the benefit of economic development during distressed times, it is necessary to immediately adopt the foregoing exceptions, modifications and additions to the California Residential Code. Additionally, the California Residential Code becomes effective on January 1, 2011 and the amendments to that code as reflected herein must be adopted by the City Council and become effective as soon as possible. The Council, therefore, with the Mayor's concurrence, adopts this ordinance to become effective upon publication pursuant to Los Angeles City Charter Section 253.

Sec. 3. The City Clerk shall certify to the passage of this ordinance and have it published in accordance with Council policy, either in a daily newspaper circulated in the City of Los Angeles or by posting for ten days in three public places in the City of Los Angeles: one copy on the bulletin board located at the Main Street entrance to the Los Angeles City Hall; one copy on the bulletin board located at the Main Street entrance to the Los Angeles City Hall East; and one copy on the bulletin board located at the Temple Street entrance to the Los Angeles County Hall of Records.

I hereby certify that this ordinance was passed by the Council of the City of Los Angeles, **by a vote of not less than three-fourths** of all its members, at its meeting of _____.

JUNE LAGMAY, City Clerk

By _____ Deputy

Approved _____

Mayor

Approved as to Form and Legality

CARMEN A. TRUTANICH, City Attorney

By 
KIM RODGERS WESTHOFF
Deputy City Attorney

Date 3/21/2011

File No(s). CF 10-2335