

BASELINE MANSIONIZATION (BMO) & BASELINE HILLSIDE (BHO) AMENDMENT

- Modify R1 building envelope:
 - Encroachment plane
 - Side wall articulation
 - Roof deck setback along side yard
- Limit R1 driveway width in non-Hillside areas
- Hillside Area only:
 - Reduce exemptions to grading & hauling limits
 - Limit hauling activities to 9 a.m. – 3 p.m., Monday-Friday
 - Reduce guaranteed minimum RFA from 1,000 to 800 SF
- Reduce Residential Floor Area (RFA) exemptions
- Reduce R1 Floor Area Ratio (FAR) to 0.45 for all lot sizes
- Eliminate all 20% RFA bonus options in R1 Zone
- Eliminate green building bonus option in RA, RE, RS Zones

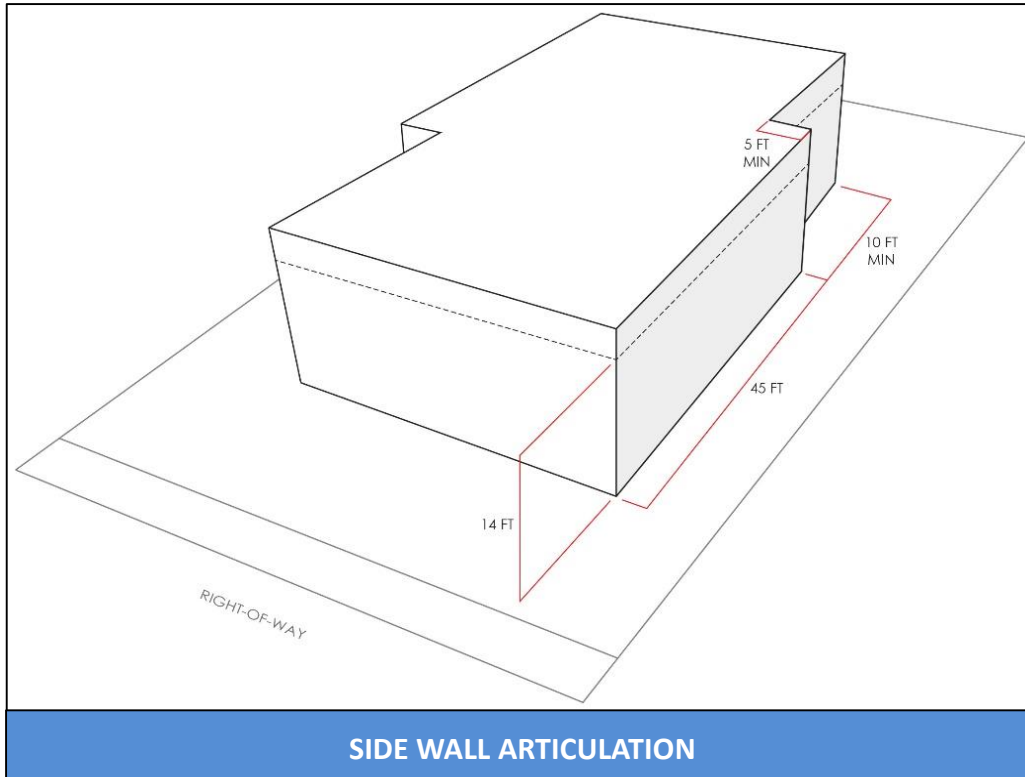

SIDE WALL ARTICULATION



- Offset/plane break for walls over 14' high & 45' long
- At least 5' deep beyond required setback
- At least 10' long
- Wall height measured at building perimeter

