

# TRANSMITTAL

To:

**THE COUNCIL**

Date: 11/29/2017

From:

**THE MAYOR**

**TRANSMITTED FOR YOUR CONSIDERATION. PLEASE SEE ATTACHED.**



(Ana Guerrero) for

**ERIC GARCETTI**  
Mayor

# LOS ANGELES POLICE COMMISSION

BOARD OF  
POLICE COMMISSIONERS

STEVE SOBOROFF  
PRESIDENT

MATTEW M. JOHNSON  
VICE PRESIDENT

SANDRA FIGUEROA-VILLA  
SHANE MURPHY GOLDSMITH  
CYNTHIA McCLAIN-HILL

MARIA SILVA  
COMMISSION EXECUTIVE ASSISTANT II



**ERIC GARCETTI**  
Mayor

RICHARD M. TEFANK  
EXECUTIVE DIRECTOR

DJANGO SIBLEY  
ACTING INSPECTOR GENERAL

EXECUTIVE OFFICE  
POLICE ADMINISTRATION BUILDING  
100 WEST FIRST STREET, SUITE 134  
LOS ANGELES, CA 90012-4112

(213) 236-1400 PHONE  
(213) 236-1410 FAX  
(213) 236-1440 TDD

November 21, 2017

BPC #17-0452

The Honorable Eric Garcetti  
Mayor, City of Los Angeles  
City Hall, Room 303  
Los Angeles, California 90012

Attention Mandy Morales

Dear Honorable Mayor:

RE: DONATION OF EXPLOSIVE TRANSPORT MAGAZINES, VALUED AT \$19,400.00,  
FROM MCDANIEL, INC., FOR THE BENEFIT OF THE LOS ANGELES POLICE  
DEPARTMENT'S METROPOLITAN DIVISION, SPECIAL WEAPONS AND TACTICS  
TEAM (SWAT).

At the regular meeting of the Board of Police Commissioners held Tuesday, November 21, 2017,  
the Board RECEIVED the Department's report relative to the above matter.

The Board requests, subject to your approval, that this matter be forwarded to City Council for their  
approval.

Respectfully,

BOARD OF POLICE COMMISSIONERS

MARIA SILVA  
Commission Executive Assistant II

Attachment

c: Chief of Police  
ASB

INTRADEPARTMENTAL CORRESPONDENCE

17-0552  
**RECEIVED**

NOV 21 2017

November 16, 2017

1.10

**REVIEWED**

**TO:** The Honorable Board of Police Commissioners

**FROM:** Chief of Police

*Richard M. Tefank*  
**RICHARD M. TEFANK**  
CHIEF OF POLICE  
11/17/17  
DATE

**SUBJECT:** APPROVAL OF NON-MONETARY DONATION

**RECOMMENDED ACTION**

- 1. That the Board of Police Commissioners APPROVE the Department's Report and TRANSMIT to the Mayor and City Council for ACCEPTANCE the donation of explosive transport magazines valued at \$19,400 for Metropolitan Division.

| <u>DONOR INFORMATION:</u>                                                                                                            | <u>ITEM:</u>                                                                   | <u>AMOUNT:</u> |
|--------------------------------------------------------------------------------------------------------------------------------------|--------------------------------------------------------------------------------|----------------|
| McDaniel, Inc. (#286-17)<br>Mr. Tim McDaniel, President<br>10807 Monte Vista Avenue<br>Montclair, California 91763<br>(909) 591-8353 | 2-Large explosive transport magazines<br>9-Small explosive transport magazines | \$19,400       |

**DISCUSSION**

This donation is for the benefit of the Metropolitan Division Special Weapons and Tactics (SWAT) Team. Alcohol, Tobacco and Firearms (ATF) regulations require these specific magazines to safely transport charges and detonators needed during explosive breaching operations. The donation of these items will allow all SWAT supervisory vehicles to transport explosive charges, reducing tactical and logistical delays when deployment and immediate accessibility are needed. The Los Angeles Police Department (Department) Bomb Squad reviewed and approved the items and found them to be consistent with ATF guidelines.

No expressed or implied commitments or promises were made to the donor or representatives of the donor. The donor will not receive any preferential treatment, endorsement, or recommendation; and the donor is not allowed the use of any Department patents.

Administrative Services Bureau has reviewed the donation and determined that it has been submitted in accordance with Section 5.467 et seq. of the Los Angeles Administrative Code, which provides for the receipt and acceptance of donations to the Department.

The Honorable Board of Police Commissioners

Page 2

1.10

If you have any questions, please contact Lieutenant Ruben Lopez, SWAT, Metropolitan Division, at (213) 305-4631.

Respectfully,

A handwritten signature in blue ink, appearing to be 'C. Beck', written over the printed name.

CHARLIE BECK  
Chief of Police

## INTRADEPARTMENTAL CORRESPONDENCE

September 22, 2017  
16.3

**TO:** Commanding Officer, Administrative Services Bureau

**FROM:** Commanding Officer, Metropolitan Division

**SUBJECT:** REQUEST TO ACCEPT DONATION

It is requested that Administrative Services Bureau approve and forward correspondence to the Board of Police Commissioners to accept the unsolicited donation of:

| <b>Quantity</b> | <b>Type</b>                          | <b>Dimensions</b>        |
|-----------------|--------------------------------------|--------------------------|
| 2               | IME 22 Explosive Transport Magazines | 90"L x 12"W x 7.5"H      |
| 9               | IME 22 Explosive Transport Magazines | 26.5"L x 24.5"W x 13.5"H |

The donation was received on August 27, 2017, and will benefit the Metropolitan Division Special Weapons and Tactics (SWAT) team. These specific explosive transport magazines are required by Alcohol, Tobacco and Firearms (ATF) regulations to safely transport related charges and detonators, which are needed during explosive breaching operations (i.e. Hostage Rescue Tactics).

The addition of these explosive transport magazines will make explosive charges readily available in all supervisory police vehicles assigned to SWAT. *Currently, only the responding Lieutenant has this capability.* Because of the limited availability/inventory currently available there are logistical delays when deployment and immediate accessibility are needed. With the additional inventory and increased availability, we will have taken the appropriate steps to eliminate and/or reduce these tactical delays when a breaching deployment is imminent.

The addition of these boxes to additional personnel does not change any existing policy and procedure in its use or the approval process required for its deployment

The build specifications provided to McDaniel, Inc. were reviewed by the Los Angeles Police Department's (LAPD) Bomb Squad and approved for fabrication and were found to be consistent with ATF guidelines (ATF P 5400.7).

**DONOR INFORMATION:**

McDaniel, Inc.  
Tim McDaniel, President  
10807 Monte Vista Avenue  
(O) 909-591-8353  
(M) 909-721-7321  
www.mcdanielsinc.net

**AMOUNT:**

\$19,400.00

All possible conflicts of interest have been researched. No expressed or implied commitment or promise was made to the donor or representatives of the donor; the donor will not receive any preferential treatment, endorsement, or recommendation; and the donor is not allowed the use of any LAPD patent. Also, there will be no additional costs for maintenance.

If you should have any questions or require additional information, please have a member of your staff contact Lieutenant Ruben Lopez, SWAT, at (213) 305-4631.



JONATHAN L. TIPPET, Captain  
Commanding Officer  
Metropolitan Division

Attachments

APPROVED:



HORRACE FRANK, Deputy Chief  
Commanding Officer  
Counter-Terrorism and Special Operations Bureau

APPROVED:

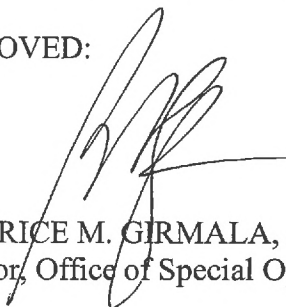

BEATRICE M. GIRMALA, Assistant Chief  
Director, Office of Special Operations



## **IME 22 TRANSPORT BOXES**

- 9- Small Explosive Transportation Boxes**
- 2- Large Explosive Transportation Boxes**

**Donated By:**

**McDaniel, Inc.**

**Tim McDaniel, President**

**10807 Monte Vista Avenue**

**(O) 909-591-8353**

**(M) 909-721-7321**

**[www.mcdanielsinc.net](http://www.mcdanielsinc.net)**

**Total Value of Donation: \$19,400.00**



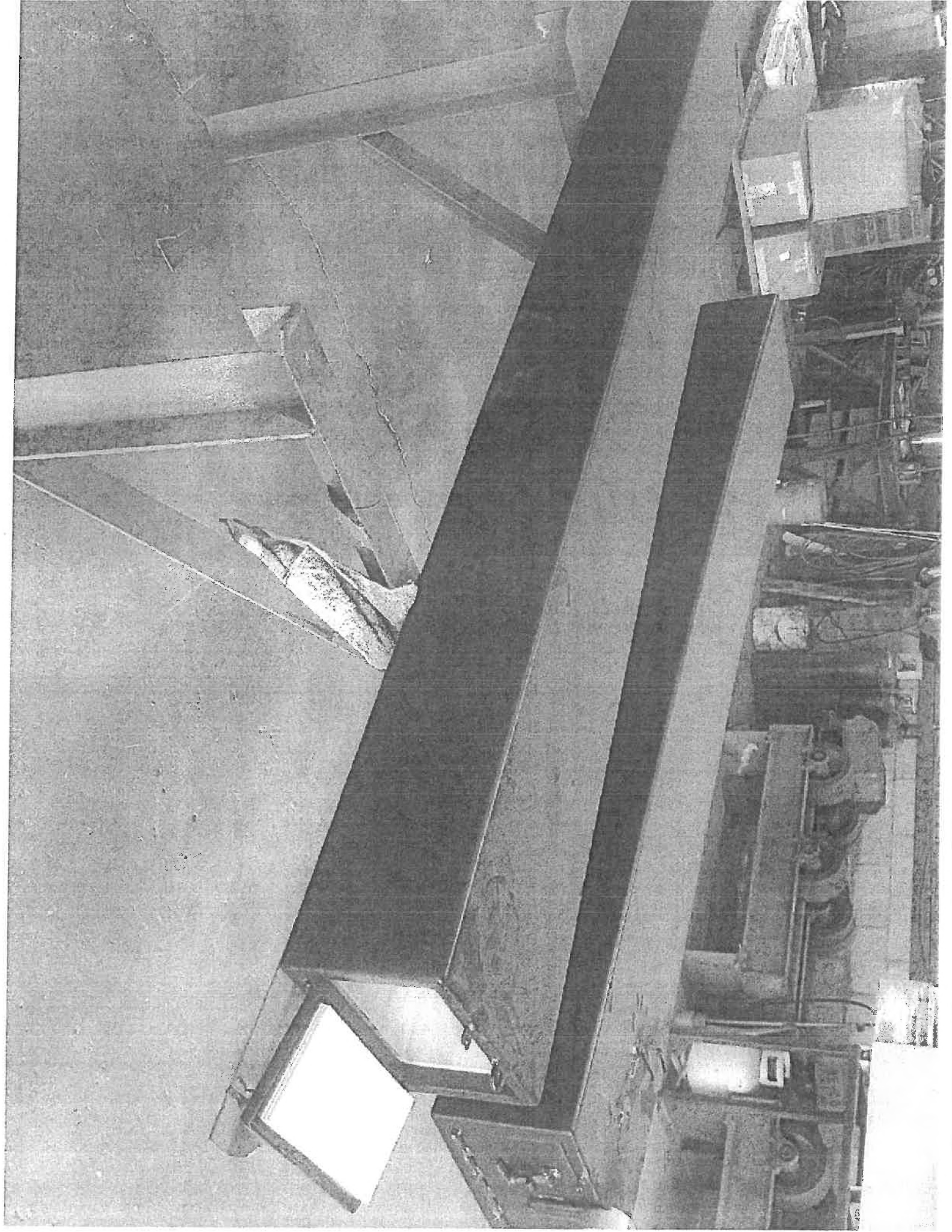

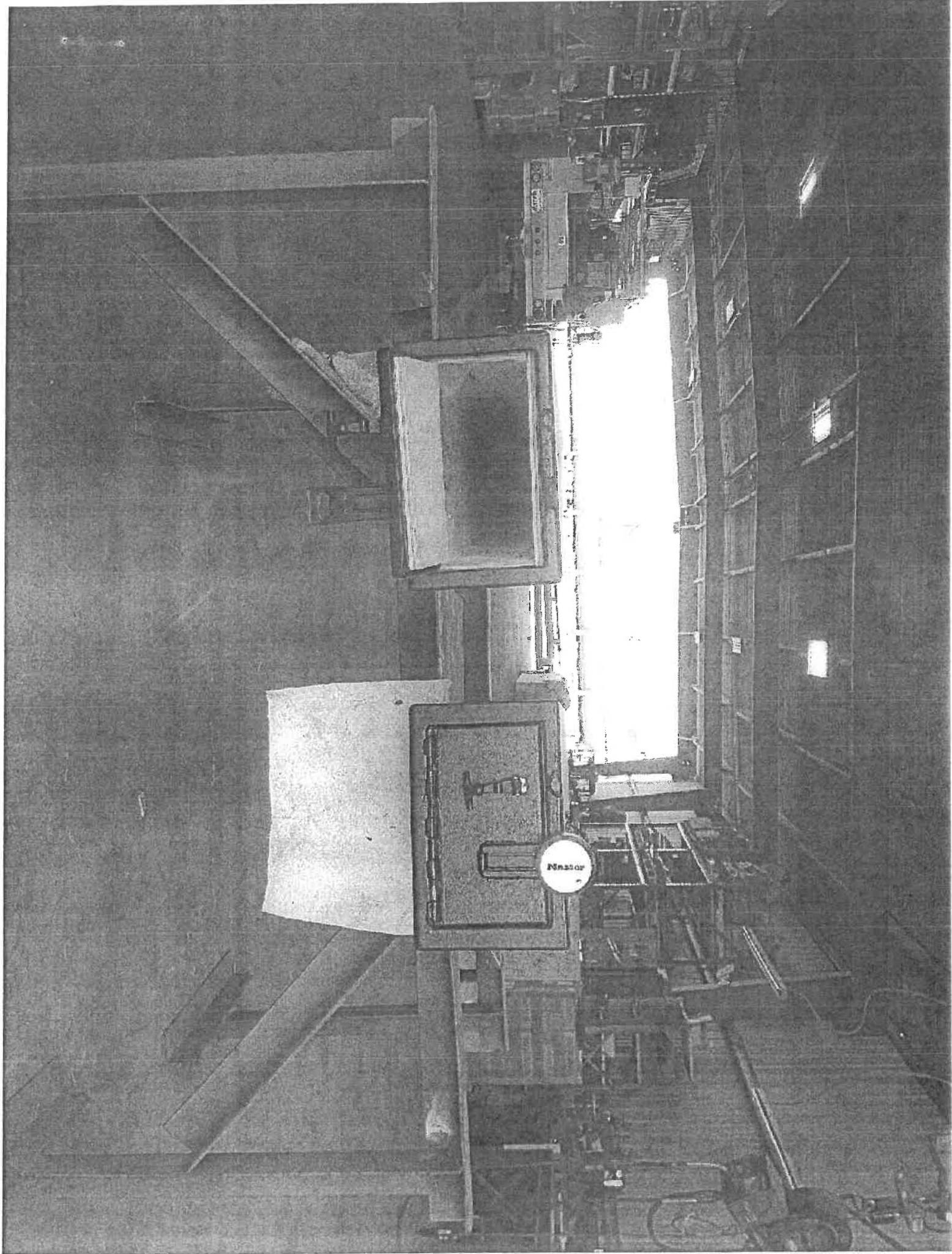

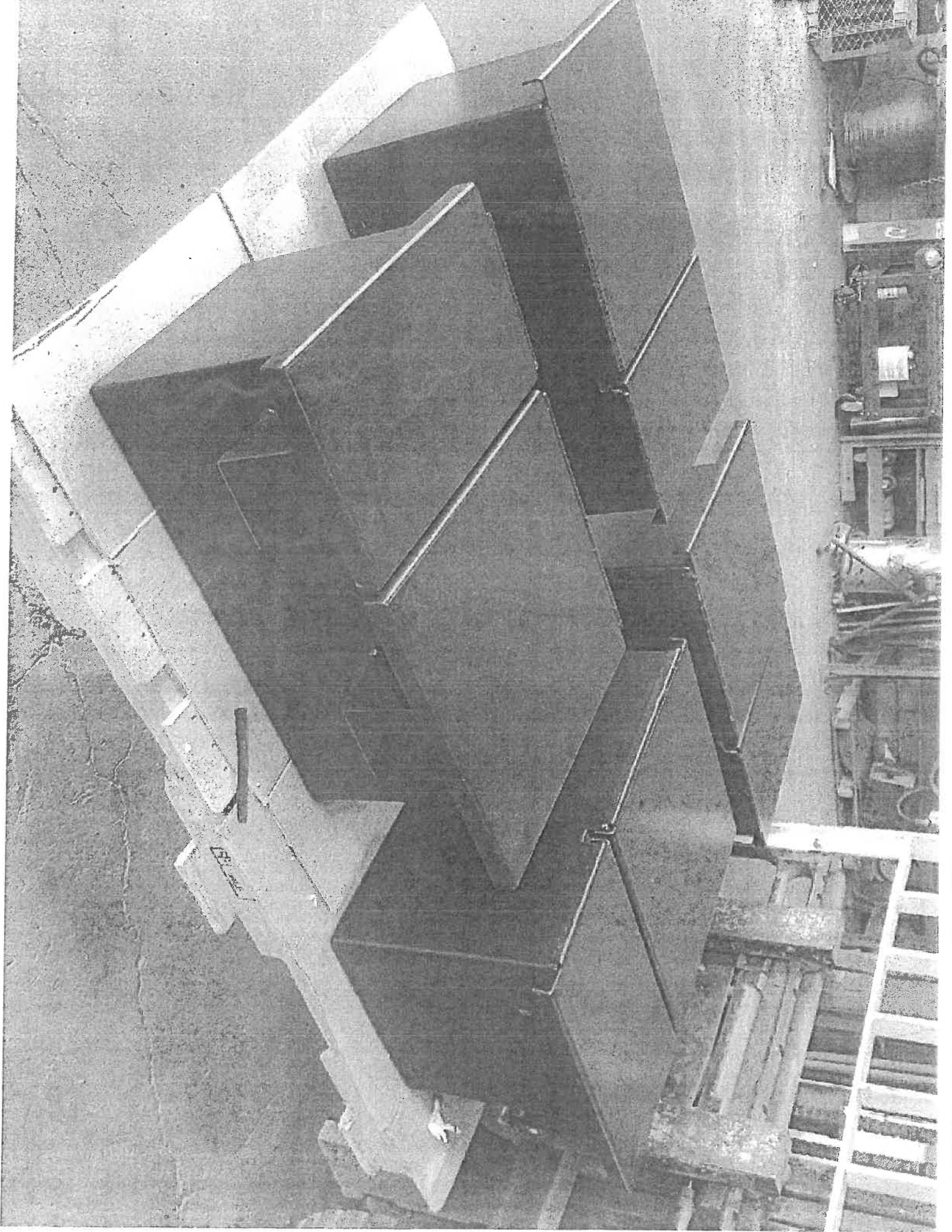

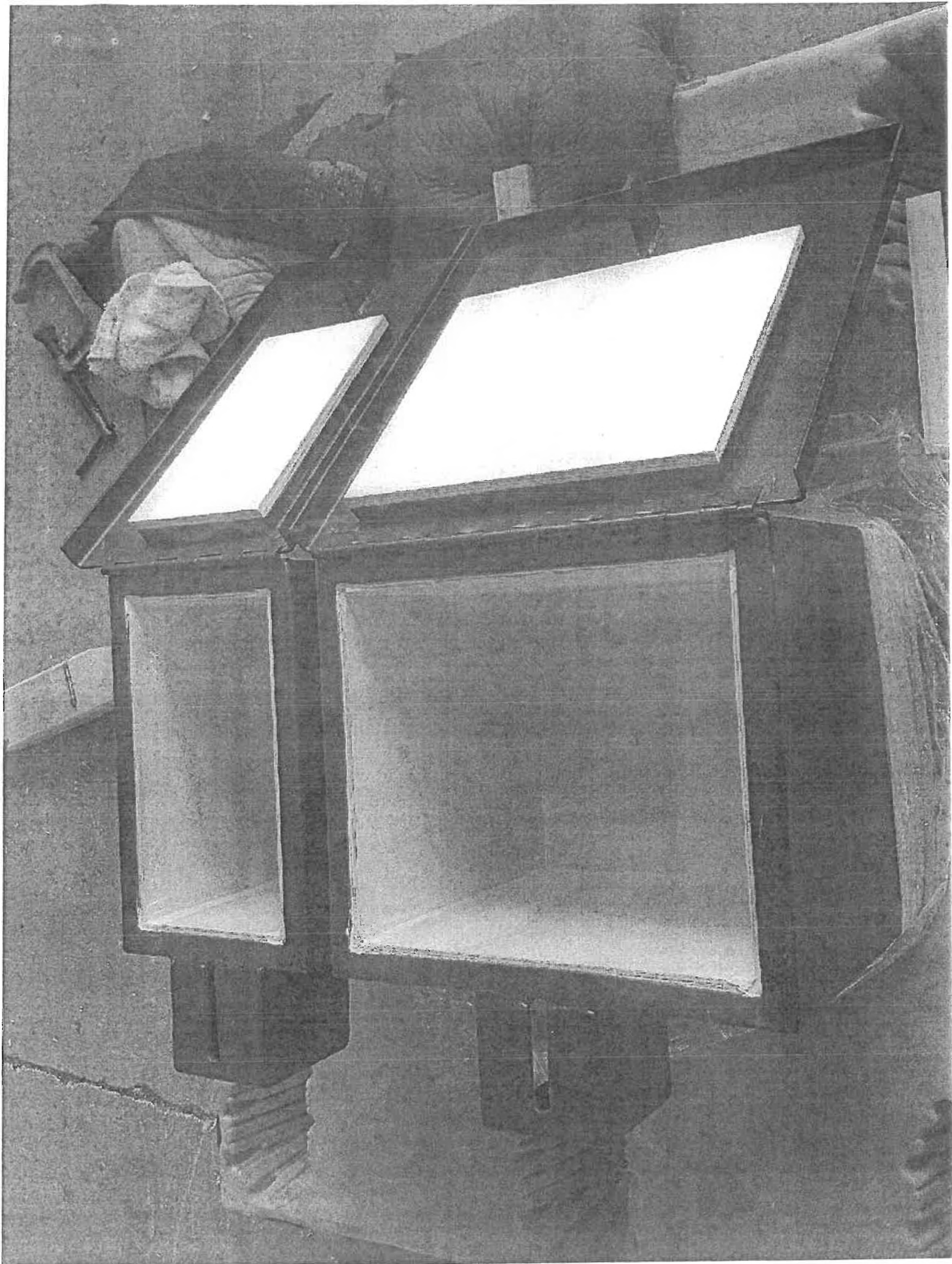

# Southwest Explosives

Officer Rich Nagatoshi  
Los Angeles Police Dept. / SWAT  
2029 N. Main Street  
Los Angeles, CA 90039

December 29, 2016

e-mail: rich.nagatoshi@lapd.lacity.org

Dear Officer Nagatoshi,

Thank you for requesting a quote for explosives storage magazine for the Los Angeles Police Department- SWAT Unit. The price is as follows:

## PRICE QUOTE

|                                                                |                   |
|----------------------------------------------------------------|-------------------|
| 2 each- IME 22 Transport Magazine, approx. 90"L x 12"W x 7.5"H |                   |
| @ \$ 2950.00/ea                                                | \$ 5900.00        |
| <u>Delivery to LAPD facility:</u>                              | <u>\$ 350.00</u>  |
| <u>Sales Tax 9.00%</u>                                         | <u>562.50</u>     |
| <b>Grand Total</b>                                             | <b>\$ 6812.50</b> |

\* \* \* \* \*

Terms are COD. Boxes are to be painted black.

If there is anything else you need, please don't hesitate in calling me.

Yours truly,

Jeff Brust

**Post Office Box 1677- Lakeside, CA 92040**  
**Phone (619) 443-8178 Fax (619) 443-8129 License #650989**



|                    |                       |                     |                   |
|--------------------|-----------------------|---------------------|-------------------|
| To: Rich Nagatoshi | Attn:                 | Phone:              | Fax:              |
| From: Jeff Brust   | Date: October 2, 2015 | Phone: 619-726-7288 | Fax: 619-443-8129 |

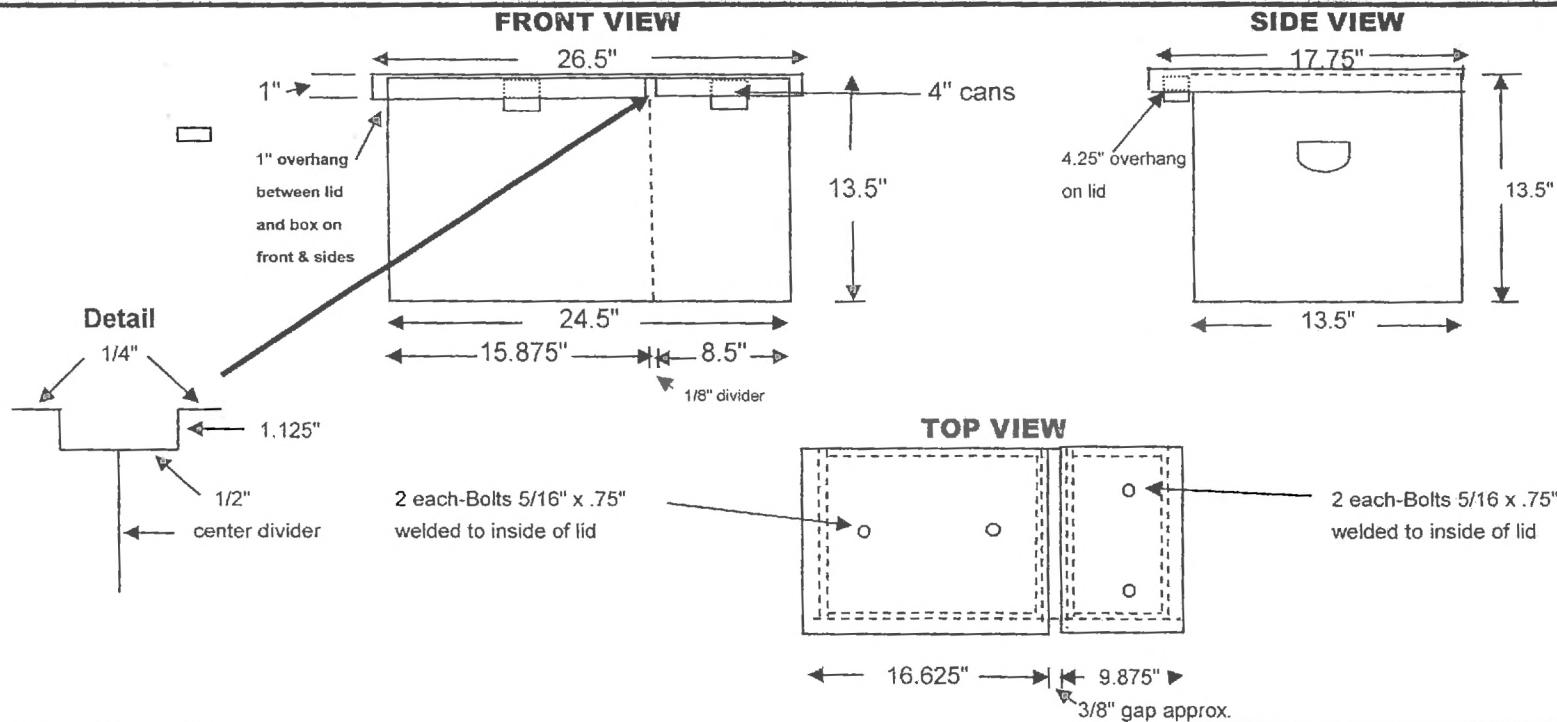

Handwritten mark: a square with an 'X' and the number '9' next to it.

**SPECIFICATIONS:**

- 1) Box and lid to be .125" min. carbon steel.
- 2) All finished dimensions are to be + or - .065".
- 3) Lids to have 1" overhang on sides & 4.25" in front & flush in back as per drawing.
- 4) Inside top edge of both compartments to be bent inward @ 90 degrees x .750".
- 5) The lid to rise .500" upward when lid is locked with padlock.
- 6) The back of the lid to be flush with back of box with 2" welded continues hinge (3/16" pin & 1" knuckle length).
- 7) The locking cans are to be 4x4 (enclosed on 5 sides) w/opening toward the side outside & welded to box.
- 8) The locking pin to be .375" thick x 1" flat bar welded to lid & hole to accommodate a .375" dia. shackle for pad lock.
- 9) Weld to inside of lid 4 each bolts as per drawing.
- 10) Box and lids to be square.
- 11) This completed magazine meets BATF Type 3 spec's and DOT IME 22 spec's.

| Inside Finished Dimensions                |
|-------------------------------------------|
| (Finished and Lined)                      |
| Small Compartment- 6.5"Lx11.5"Wx11.5"H    |
| Large Compartment- 13.875"Lx11.5"Wx11.5"H |
| Box to be painted white                   |

**Cost: \$1,500.00** each/4 units

DRAWING AND SPEC'S APPROVED BY: \_\_\_\_\_

DATE: \_\_\_\_\_

From: Jeff Brust  
Cell# 619-726-7288  
Email: jeff@mjbaxter.com

# IME 22 Transport Box

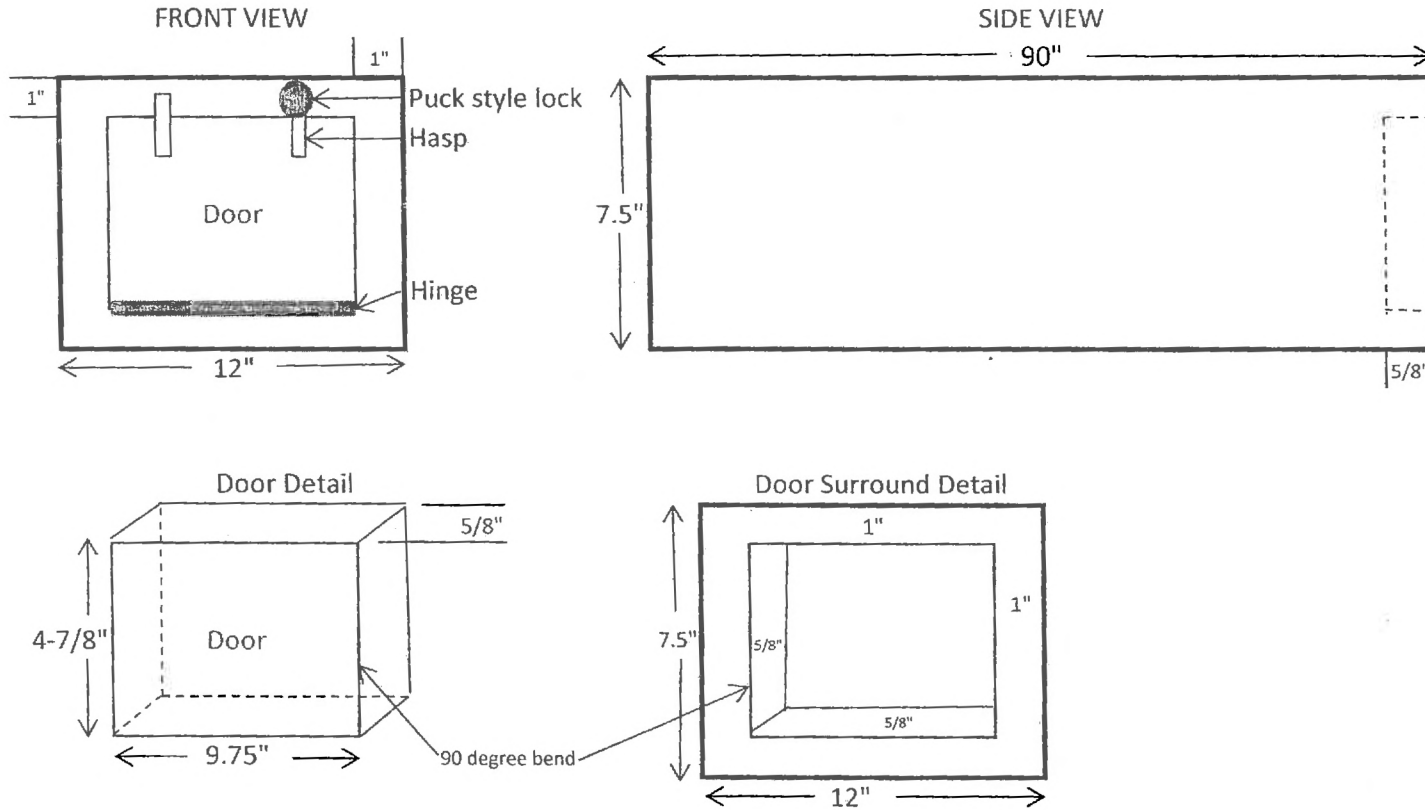

## SPECIFICATIONS:

- Box and lid to be .125" carbon steel
- Inside door and door surround to be bent @ 90 degree x 5/8".
- Hasp and staple to be extra heavy-duty and configured to except a "puck" style lock.
- Box and lid to be square
- Door hinge to be welded to the door and door-surround in the space created

**Total Price: \$ 5900.00 for 2 Boxes**

Drawing and Spec's Approved By: \_\_\_\_\_ Date: \_\_\_\_\_