

ANPP HASSAYAMPA SWITCHYARD
INTERCONNECTION AGREEMENT
AMONG
ARIZONA PUBLIC SERVICE COMPANY
THE CITY OF LOS ANGELES BY AND THROUGH
THE DEPARTMENT OF WATER AND POWER
EL PASO ELECTRIC COMPANY
PUBLIC SERVICE COMPANY OF NEW MEXICO
SALT RIVER PROJECT AGRICULTURAL IMPROVEMENT AND POWER DISTRICT
SOUTHERN CALIFORNIA PUBLIC POWER AUTHORITY
SOUTHERN CALIFORNIA EDISON COMPANY
AND
SUN STREAMS 2, LLC

**ANPP HASSAYAMPA SWITCHYARD
INTERCONNECTION AGREEMENT**

Table of Contents

1.	PARTIES:	1
2.	RECITALS:	1
3.	AGREEMENT:	2
4.	DEFINITIONS:	2
5.	EFFECTIVE DATE AND TERMINATION:	9
6.	OWNERSHIP-LIKE RIGHTS GRANTED AND RESERVED:	10
7.	OWNERSHIP:	15
8.	OPERATION OF HASSAYAMPA SWITCHYARD:	16
9.	OPERATION:	20
10.	SCHEDULING AND DISPATCHING:	23
11.	COST RESPONSIBILITY:	23
12.	BILLING AND PAYMENT:	26
13.	COORDINATION AND EXCHANGE OF INFORMATION:	30
14.	DISPOSITION OF FACILITIES:	31
15.	TAXES:	31
16.	INSURANCE:	36
17.	INDEMNITY, LIABILITY LIMITS AND DAMAGE DISCLAIMERS:	38
18.	UNCONTROLLABLE FORCES:	39
19.	RELATIONSHIP OF THE PARTIES:	40
20.	SUCCESSORS AND ASSIGNS:	40
21.	AUDITS:	41
22.	DEFAULTS:	42
23.	DISPUTE RESOLUTION:	44
24.	NONDEDICATION OF FACILITIES:	44
25.	REGULATORY APPROVALS:	45
26.	GOVERNING LAW AND VENUE:	45
27.	NOTICES:	45
28.	ANPP SWITCHYARD PARTICIPANTS' OTHER AGREEMENT:	45
29.	ENTIRE AGREEMENT:	46
30.	SECTION HEADINGS AND DEFINITIONS:	47
31.	GENERAL PROVISIONS:	47
32.	EXECUTION:	48
33.	SIGNATURE CLAUSE:	48

APPENDICES

- Appendix A Interconnection Facilities
- Appendix B Milestones
- Appendix C Interconnection Details
- Appendix D Security Arrangement Details
- Appendix E Commercial Operation Date
- Appendix F Addresses for Delivery of Notices and Billings

EXHIBITS

- Exhibit 1 Common Facilities
- Exhibit 2 Common Facilities Use Fee
- Exhibit 3 HAA Cost Responsibility Ratio (HAA CRR)
- Exhibit 4 PV Switchyard Cost Responsibility Ratio (PV CRR)
- Exhibit 5 Operating Work
- Exhibit 6 Easement
- Exhibit 7 Insurance
- Exhibit 8 Mitigation Facility Fee
- Exhibit 9 Interconnection Costs

**ANPP HASSAYAMPA SWITCHYARD
INTERCONNECTION AGREEMENT**

1. PARTIES:

The Parties to this ANPP HASSAYAMPA SWITCHYARD INTERCONNECTION AGREEMENT (this "Agreement") are: ARIZONA PUBLIC SERVICE COMPANY ("APS"), an Arizona corporation; EL PASO ELECTRIC COMPANY ("EPE"), a Texas corporation; THE CITY OF LOS ANGELES BY AND THROUGH THE DEPARTMENT OF WATER AND POWER ("LADWP"), a department organized and existing by virtue of and under the Charter of the City of Los Angeles, a municipal corporation of the State of California; PUBLIC SERVICE COMPANY OF NEW MEXICO ("PNM"), a New Mexico corporation; SALT RIVER PROJECT AGRICULTURAL IMPROVEMENT AND POWER DISTRICT ("SRP"), an agricultural improvement district organized and existing under the laws of the State of Arizona; SOUTHERN CALIFORNIA PUBLIC POWER AUTHORITY ("SCPPA"), a public entity organized and existing under and by virtue of the laws of the State of California; SOUTHERN CALIFORNIA EDISON COMPANY ("SCE"), a California corporation; and SUN STREAMS 2, LLC ("interconnector"), a Delaware limited liability company; individually referred to as "Party" and collectively as "Parties".

2. RECITALS:

This Agreement is made with reference to the following facts, among others:

- 2.1. The Interconnector intends to construct and operate its Generating Facility for the purpose of generating electric energy for its own use, selling electric power at wholesale, or both.
- 2.2. The ANPP Switchyard Participants operate the Hassayampa Switchyard, the existing ANPP Switchyard, and the string bus facilities connecting them, as a Common Bus Arrangement.
- 2.3. The ANPP Switchyard Participants entered into that certain ANPP Hassayampa Interconnection Agreement with an effective date of January 8, 2019 ("SS1 IA") which authorizes the Sun Streams 1 Project ("SS1") to interconnect its generating facilities via Interconnector's Interconnection Facilities and JPP Interconnection Facilities as defined in and to be constructed according to the terms and conditions of said SS1 IA.
- 2.4. The Interconnector has entered into a shared facilities agreement pursuant to which the Interconnector has agreed to share the use of its Interconnector's Interconnection Facilities and JPP Interconnection Facilities with SS1 and future SS Entities.

- 2.5. The Interconnector desires to interconnect its Generating Facility to the Hassayampa Switchyard.
- 2.6. The ANPP Switchyard Participants are willing to provide such interconnection under the terms and conditions contained in this Agreement.
- 2.7. The Interconnector understands that (i) this Agreement does not provide any transmission services, balancing authority area services, distribution services, or ancillary services, (ii) this Agreement does not obligate the ANPP Switchyard Participants to purchase, sell, transmit, or otherwise provide any other rights with respect to power and energy generated by or required for the Generating Facility, other than as provided herein with respect to the Common Bus Arrangement, and (iii) this Agreement does not give the Interconnector the right to inject power and energy into the Common Bus, except and only to the extent that all necessary arrangements for transmission rights and service, including transmission-related mitigation requirements, if any, are in place for the delivery thereof.
- 2.8. Certain costs and reimbursement rights relating to the Common Bus and the JPP Interconnection Facilities are allocated on the basis of the number of Connections. Because Interconnector shares a single Connection with other SS entities, these costs and reimbursements will be assessed or paid only once on behalf of all SS Entities. To mitigate the administrative burden on Operator, these common costs will be assessed and these common reimbursements will be paid pursuant to the Shared Facilities Responsible Project IA on behalf of Interconnector and other SS Entities.

3. AGREEMENT:

In consideration of these premises and of the mutual covenants contained herein, the Parties agree as follows:

4. DEFINITIONS:

The following terms, whether in the singular or plural, when initially capitalized in this Agreement or in amendments or in appendices or exhibits thereto, shall have the meanings specified:

- 4.1. Accounting Practice: Generally accepted accounting principles, in accordance with the FERC's "Uniform System of Accounts Prescribed for Public Utilities and Licensees," in effect as of the date of this Agreement, and as such system of accounts may be amended and in effect from time to time.
- 4.2. Administrative Committee: The ANPP High Voltage Switchyard Administrative Committee as established in the ANPP Switchyard Participation Agreement.

- 4.3. Agreement: This ANPP Hassayampa Switchyard Interconnection Agreement, as such may be amended, supplemented, or revised from time to time.
- 4.4. ANPP: The Arizona Nuclear Power Project.
- 4.5. ANPP Switchyard: The ANPP High Voltage Switchyard at the Palo Verde Nuclear Generating Station near Wintersburg, Arizona, which is collectively comprised of the Palo Verde Switchyard and the Hassayampa Switchyard.
- 4.6. ANPP Switchyard Participants: APS, EPE, LADWP, PNM, SCE, SCPPA, and SRP, and their respective successors, also referred to from time to time as "Joint Participants."
- 4.7. ANPP Switchyard Participation Agreement: *The ANPP High Voltage Switchyard Participation Agreement among the ANPP High Voltage Switchyard Participants*, effective as of August 20, 1981, as amended or supplemented from time to time.
- 4.8. Applicable Requirements: Any Law; any standards, procedures or requirements of (i) WECC, (ii) any other Person that has the authority to control the operation of the applicable transmission system, or (iii) any other Person that are binding on the Common Bus or on its operation or on the Operator or on any ANPP Switchyard Participant in a way that affects the Common Bus or the Common Bus Arrangement; any standards, procedures or other requirements adopted by the Operator or the E&O Committee in writing pursuant to any provision of this Agreement and in conformance with Good Utility Practice; in each case as amended from time to time and whether now existing or hereafter imposed or arising.
- 4.9. Authorized Representative(s): The Authorized Representative(s) designated pursuant to Section 13.1 of this Agreement.
- 4.10. Business Day: Any day other than a Saturday, Sunday or legal holiday in the State of Arizona.
- 4.11. Capital Improvements: Any Unit of Property that is added to the Common Bus, the Hassayampa Interconnection Facilities or the JPP Interconnection Facilities, the enlargement or betterment of any Unit of Property constituting a part of the Common Bus, the Hassayampa Interconnection Facilities or the JPP Interconnection Facilities, and the replacement of any Unit of Property constituting a part of the Common Bus, the Hassayampa Interconnection Facilities or the JPP Interconnection Facilities, irrespective of whether such replacement constitutes an enlargement or betterment of that which it replaces; which additions, betterments, enlargements and replacements in accordance with Accounting Practice would be capitalized.

- 4.12. Commercial Operation: The status of a Generating Facility that has commenced generating electricity for sale, excluding electricity generated during Trial Operation.
- 4.13. Commercial Operation Date: The date on which the Generating Facility commences Commercial Operation as certified in a letter from Interconnector to Operator, substantially in the form attached hereto as Appendix E COMMERCIAL OPERATION DATE to this Agreement.
- 4.14. Common Bus: The ANPP Switchyard, and the string bus facilities connecting the Palo Verde Switchyard and the Hassayampa Switchyard that collectively make up the ANPP Switchyard, and any Capital Improvements thereto.
- 4.15. Common Bus Arrangement: The delivery, sale, purchase, receipt and/or exchange of power and energy at any point within the Common Bus without a transmission charge, transmission credit, reservation, or schedule for transactions or any portions thereof conducted within the Common Bus.
- 4.16. Connection: Each 500 kV termination in the Hassayampa Switchyard, as shown in Appendix C, Figure 4, HASSAYAMPA, attached hereto, as such Figure may be revised by the Operator from time to time in accordance with Section 31.5 of this Agreement to accurately reflect the then-current 500 kV terminations in the Hassayampa Switchyard.
- 4.17. Constant Dollars: A quantity calculated by multiplying a stated amount of money by a fraction the numerator of which is the United States Department of Labor Consumer Price Index for all Urban Consumers (the "Index") as of the latest date on which such Index was published prior to the date of such calculation and the denominator of which is the Index as of the Effective Date, in each case adjusted to the same base year.
- 4.18. Construction Costs: The "Construction Costs" excluding "Additional Costs" as such terms are defined in the Funding Agreement.
- 4.19. E&O Committee: The ANPP High Voltage Switchyard Engineering and Operating Committee as established in the ANPP Switchyard Participation Agreement.
- 4.20. Effective Date: The Effective Date shall have the meaning set forth in Section 5.1 of this Agreement.
- 4.21. FERC: The Federal Energy Regulatory Commission or any successor agency.
- 4.22. Funding Agreement: The *Funding Agreement for the Development of a Satellite Switchyard to the ANPP High Voltage Switchyard Between Participating Interconnectors and Salt River Project Agricultural*

Improvement and Power District, effective as of May 26, 2000, together with the *First Addendum to the Funding Agreement*, dated as of January 16, 2001, and as further amended or supplemented from time to time.

- 4.23. Generating Facility: The generating unit(s) described in Appendix C, INTERCONNECTION DETAILS, attached hereto, and associated facilities.
- 4.24. Good Utility Practice: Any of the practices, methods and acts engaged in or approved by a significant portion of the electric utility industry within the operating area of the WECC during the relevant time period, or any of the practices, methods and acts which, in the exercise of reasonable judgment in light of the facts known at the time the decision was made, could have been expected to accomplish the desired result at a reasonable cost consistent with good business practices, reliability, safety, and expedition. Good Utility Practice is not intended to be limited to the optimum practice, method, or act to the exclusion of all others, but rather includes any acceptable practices, methods, or acts generally accepted in the WECC region.
- 4.25. Governmental Authority: Any federal, state, local or other governmental regulatory or administrative agency or its staff, court, commission, department, board, or other governmental subdivision, legislature, rulemaking board, tribunal, or other governmental authority having jurisdiction over the Parties, their respective facilities, or their respective services they provide, and exercising or entitled to exercise any administrative, executive, police, or taxing authority or power; provided, however, that such term does not include Interconnector, ANPP Switchyard Participants, Operator or any affiliate thereof.
- 4.26. Hassayampa Cost Responsibility Ratio ("Hassayampa CRR"): The ratio of responsibility for costs allocated to the Hassayampa Switchyard as determined by the Operator from time to time pursuant to Section 8.1.4 of this Agreement, and in accordance with Exhibit 3, HAA COST RESPONSIBILITY RATIO (HAA CRR), attached hereto.
- 4.27. Hassayampa Interconnection Facilities: The equipment and facilities located within the boundaries of the Hassayampa Switchyard that connect the Hassayampa Interconnectors' interconnection tie lines to the Hassayampa Switchyard, excluding the JPP Interconnection Facilities. (The term "Hassayampa Interconnection Facilities" includes but is not limited to said equipment and facilities as initially constructed and installed and all Capital Improvement made thereto.)
- 4.28. Hassayampa Interconnectors: Any Person that has executed an interconnection agreement to connect its generating and/or transmission facilities to the Hassayampa Switchyard.

- 4.29. Hassayampa Switchyard (“HAA”): The 500 kV “satellite” switchyard approximately three (3) miles south of the PV Switchyard including all land, facilities and equipment appurtenant thereto, but excluding the Hassayampa Interconnection Facilities and the JPP Interconnection Facilities. (The term “Hassayampa Switchyard” includes but is not limited to said equipment and facilities as initially constructed and installed and all Capital Improvements made thereto.)
- 4.30. In-Service Date: The date upon which the Generating Facility is initially synchronized and upon which Trial Operation begins.
- 4.31. Interconnection Facilities In-Service Date: The initial date upon which the JPP Interconnection Facilities and any HAA facilities necessary to operate such JPP Interconnection Facilities can reasonably be expected to operate reliably, including the completion or schedule for the completion of any applicable Mitigation, as determined by the Operator and the E&O Committee in conformance with Good Utility Practice.
- 4.32. Intentionally Left Blank
- 4.33. Interconnector’s Interconnection Facilities: The equipment and facilities that connect the Generating Facility to the JPP Interconnection Facilities, as described in Appendix A, INTERCONNECTION FACILITIES, attached hereto, including any modifications made to the Interconnector’s Interconnection Facilities, as may be added thereto, from time to time, in accordance with Section 31.5 of this Agreement.
- 4.34. Joint Participants Project (“JPP”): The PV Switchyard and Hassayampa Switchyard.
- 4.35. JPP Interconnection Facilities: Interconnection facilities installed at HAA to facilitate the interconnection under this Agreement, as described in Appendix A, INTERCONNECTION FACILITIES, attached hereto, including any modifications made to the JPP Interconnection Facilities, as may be added thereto, from time to time, in accordance with Section 31.5 of this Agreement. The JPP Interconnection Facilities are owned by the Joint Participants.
- 4.36. Kyrene Line Owners: APS, EPE, PNM, and SRP, and their respective successors in interest.
- 4.37. Land: The land on which the HAA is located. Such Land shall be described as follows: The Northeast Quarter of Section 15 AND the West Half of the Northwest Quarter of Section 14, Township One South, Range 6 West of the Gila and Salt River Base and Meridian, Maricopa County, Arizona. Except the North 40 feet thereof.

- 4.38. Law: Any applicable governmental constitution, charter, act, statute, ordinance, code, rule, regulation, directive, interpretation, order, ruling, injunction, judgment or other executive, administrative, legislative or judicial action, as amended and in effect from time to time and whether now existing or hereafter enacted, adopted, promulgated, entered or otherwise arising.
- 4.39. Mitigation: Any construction, demolition, alteration or other action required to maintain the capability and reliability of the electric system resulting from the establishment of the HAA, the interconnection of the generating facilities of the Hassayampa Interconnectors to the HAA, the synchronization of the Hassayampa Interconnectors' generating facilities with the HAA, or any Material Alteration pursuant to Section 9.1.2 herein. For purposes of this Agreement, Mitigation shall not include transmission-related mitigation necessary for the injection or transmission of power and energy into or from the Common Bus, and nothing in this Agreement shall be deemed to make the ANPP Switchyard Participants responsible for any costs related thereto.
- 4.40. Mitigation Facility Fee: The fee to be paid by the Interconnector as determined by the Operator in accordance with Exhibit 8, MITIGATION FACILITY FEE, attached hereto.
- 4.41. Mitigation Facilities: All facilities and equipment owned, controlled, or operated by the ANPP Switchyard Participants that are constructed or installed in order to accomplish required Mitigation as that term is defined herein, including any modifications, additions or upgrades to such facilities and equipment. Mitigation Facilities shall not include the JPP Interconnection Facilities.
- 4.42. Mitigation Request: As defined in Section 11.3.
- 4.43. Non-Common Bus Interconnector: Any Person interconnecting to facilities other than those comprising the Common Bus.
- 4.44. North Gila Line Owners: APS, Imperial Irrigation District, and San Diego Gas and Electric Company, and their respective successors in interest.
- 4.45. Operating Costs: All costs described as Operating Costs in Exhibit 5, OPERATING WORK, attached hereto.
- 4.46. Operating Emergency: An unplanned event or circumstance which reduces or may reduce the capability of the Common Bus or the JPP Interconnection Facilities that would otherwise be available to the Parties under normal system operating conditions.
- 4.47. Operating Work: Any engineering, contract preparation, legal or regulatory work, purchasing, repair, supervision, recruitment, training, expediting, inspection, accounting, insurance, testing, protection, operation, use, management, retirement, reconstruction, maintenance, modification,

relocation, any work undertaken by the Operator that is required by Good Utility Practice or Applicable Requirements or necessary for the safe and reliable operation of the Common Bus and the JPP Interconnection Facilities or other work necessitated by an Operating Emergency performed in accordance with this Agreement, and all work undertaken to make Capital Improvements.

- 4.48. Operator: The Person responsible for the operation of the HAA, the duties of which are further described in Article 8 herein. As of the Effective Date, the Operator under this Agreement is SRP, acting solely as agent of and for the ANPP Switchyard Participants.
- 4.49. Original Hassayampa Interconnectors: Those generation developers who are parties to the Funding Agreement, including their successors and assigns.
- 4.50. PV Switchyard Cost Responsibility Ratio ("PV CRR"): The ratio of responsibility for costs allocated to the Palo Verde Switchyard as determined by the Operator from time to time pursuant to Section 8.1.4 herein, and in accordance with Exhibit 4 PV SWITCHYARD COST RESPONSIBILITY RATIO (PV CRR).
- 4.51. Palo Verde Switchyard ("PV Switchyard"): The 500 kV switchyard at the Palo Verde Nuclear Generating Station, including all land, facilities and equipment appurtenant thereto.
- 4.52. Person: Any natural person or legal entity of any kind, including any partnership, corporation, limited liability company, association, trust or governmental entity, officer, agency or body of any kind.
- 4.53. Pro Rata Share: The ratio utilized for allocation of certain rights and obligations to the Interconnector. Such ratio shall equal the number of Connections in the HAA to which the Interconnector is entitled under this Agreement, divided by the total number of Connections in the same switchyard (excluding the Connections associated with the tie lines to PV Switchyard, the Kyrene line, and the North Gila line).
- 4.54. Shared Facilities Manager: A Person appointed by the SS Entities to function as the agent for the SS Entities, as designated in Appendix F of this Agreement, for purposes including but not limited to coordinating notices relating to the shared Interconnector's Interconnection Facilities, receiving operating instructions and ensuring responsive actions, receiving invoices and other communications from the Operator, and implementation of tasks and actions consistent with the agent's roles and responsibilities as further described in this Agreement. Any acts or omissions of the Shared Facilities Manager arising out of or relating to this Agreement shall be deemed to be acts or omissions of the Interconnector.

- 4.55. Shared Facilities Responsible Project IA: The SS1 IA, provided, however, that if the SS1 IA is terminated, then the Shared Facilities Responsible Project IA will be this Agreement or that certain SS Entity interconnection agreement designated as the Shared Facilities Responsible Project IA by the SS Entities pursuant to notice given in accordance with Section 27.2 of this Agreement.
- 4.56. Sun Streams Entity ("SS Entity"): A party to an agreement to share ownership of the Interconnector's Interconnection Facilities described in Appendix A to the Shared Facilities Responsible Project IA that has also executed an interconnection agreement with the ANPP Switchyard Participants to interconnect generating facilities at the HAA via said Interconnector's Interconnection Facilities.
- 4.57. Sun Streams 1 Interconnection Agreement ("SS1 IA"): As defined in Section 2.3 of this Agreement.
- 4.58. Sun Streams 1 Project ("SS1 Project"): The 150MW (net) Sun Streams solar generating facility as described in Appendix C to the SS1 IA.
- 4.59. Trial Operation: The period during which Interconnector is engaged in on-site test operations and commissioning of the Generating Facility prior to Commercial Operation.
- 4.60. Unit of Property: A unit of property as described in the FERC's "List of Units of Property for Use in Connection with Uniform System of Accounts Prescribed for Public Utilities and Licensees" in effect as of January 31, 1998, as modified by FERC Order 598, effective February 5, 1998, and as may be amended from time to time.
- 4.61. WECC: The Western Electricity Coordinating Council or any successor agency.

5. EFFECTIVE DATE AND TERMINATION:

- 5.1. Effective Date: This Agreement shall become effective upon execution by the Parties, subject to acceptance by FERC, if applicable. Those ANPP Switchyard Participants who are FERC-jurisdictional shall file this Agreement with FERC upon execution in accordance with Section 5.2, if required.
- 5.2. Regulatory Filings: The ANPP Switchyard Participants, individually or collectively, shall file this Agreement (and any amendment hereto) with the appropriate Governmental Authority, if required. If no ANPP Switchyard Participant is required to file this Agreement (and any amendment hereto) with a Governmental Authority with which Interconnector is required to make such a filing, Interconnector may file this Agreement (and any amendment hereto) on its own behalf. The ANPP Switchyard Participants

or Interconnector may request that any information so provided be subject to the confidentiality provisions of Section 7.4. The Parties shall reasonably cooperate with respect to any such filing and provide any information reasonably requested by any Party as needed to comply with Applicable Requirements.

5.3. Termination: This Agreement shall terminate upon the first of the following events to occur: (i) the termination of the ANPP Switchyard Participation Agreement; (ii) written agreement of all Parties to terminate this Agreement; (iii) termination of this Agreement pursuant to Article 22 herein; or (iv) upon no less than ninety (90) calendar days' advance written notice of termination from Interconnector to Operator. For purposes of the foregoing, the ANPP Switchyard Participation Agreement shall not be deemed to have terminated at any time when (i) the ANPP Switchyard is being operated in substantially the same manner as on the Interconnection Facilities In-Service Date and (ii) an agreement pertaining to the operation of the ANPP Switchyard is in effect among the ANPP Switchyard Participants on substantially the same terms as on the Interconnection Facilities In-Service Date.

5.4. Compliance with Applicable Requirements: Notwithstanding Section 5.3, no termination shall become effective until the Parties have complied with all Applicable Requirements applicable to such termination.

5.5. Termination Costs: If a Party elects to terminate this Agreement pursuant to Section 5.3 above, the terminating Party shall pay all costs incurred (including any cancellation costs relating to orders or contracts for interconnection facilities and equipment) or charges assessed by the other Party, as of the date of the other Party's receipt of such notice of termination, that are the responsibility of such terminating party under this Agreement. In the event of termination by a Party, the Parties shall use commercially reasonable efforts to mitigate the costs, damages and charges arising as a consequence of termination. Upon termination of this Agreement:

5.5.1. With respect to any portion of the Interconnector's Interconnection Facilities, and any other facilities already installed or constructed pursuant to the terms of this Agreement, Interconnector shall be responsible for all costs associated with the removal, relocation or termination; provided, however, that such facilities will not be removed, relocated, or terminated to the extent that such facilities are still being utilized by one or more other SS Entities at the time that this Agreement is terminated.

6. OWNERSHIP-LIKE RIGHTS GRANTED AND RESERVED:

6.1. Right to Interconnect: Each ANPP Switchyard Participant, to the extent of its interest in the HAA and PV Switchyard pursuant to the ANPP Switchyard

Participation Agreement, hereby grants to the Interconnector, subject to the terms and conditions of this Agreement, the following rights that are herein defined as "Ownership-Like Rights":

- 6.1.1. The right to interconnect its Generating Facility to the HAA via the JPP Interconnection Facilities at the line bay position(s) depicted in Appendix C, Figure 1, HASSAYAMPA, attached hereto;
- 6.1.2. Except as may be required by Applicable Requirements and Laws, or as provided for in applicable joint participation, ownership or operating agreements among the ANPP Switchyard Participants, or with respect to interconnection of future generating facilities by SS Entities, or as otherwise agreed to among the Parties herein or hereafter, the JPP Interconnection Facilities shall be constructed for the sole purpose of interconnecting the Generating Facility and the other SS Entities' generating facilities to the ANPP Switchyard and shall be used for no other purpose. The Parties mutually agree that if ANPP Switchyard Participants allow a third party that is not a SS Entity to use any part of the JPP Interconnection Facilities, Interconnector will be entitled to compensation for the capital expenses it incurred in connection with those JPP Interconnection Facilities ("Capital Expenses"). These Capital Expenses will be based upon costs Interconnector incurred for one switch and one-half (1/2) of a breaker, as installed to enable the Interconnector to facilitate its own use of one switch and the other one-half (1/2) of the breaker, as is required under the breaker-and-a-half connection scheme at ANPP Switchyard. Such Capital Expenses reimbursement by a future third party's use of the switch and one-half (1/2) breaker shall be made by the ANPP Switchyard Participants to the SS Entity that is a party to the Shared Facilities Responsible Project IA by a single payment within sixty (60) business days of the receipt of payment from such third-party interconnector to the Operator. Interconnector acknowledges and agrees that the reimbursement payment described in this Section 6.1.2, when made by ANPP Switchyard Participants to the SS Entity that is a party to the Shared Facilities Responsible Project IA, fully satisfies the reimbursement obligation of the ANPP Participants under this Section 6.1.2. Under no condition shall the ANPP Switchyard Participants be liable for a failure of any SS Entity that is or becomes a party to the Shared Facilities Responsible Project IA to satisfy its obligation to disburse such reimbursement among the other SS Entities. Interconnector acknowledges and agrees that all issues or disputes between Interconnector and the SS Entity that is a party to the Shared Facilities Responsible Project IA regarding distribution of this reimbursement shall be resolved between Interconnector and the SS Entity that is a party to the Shared Facilities Responsible Project IA only. The obligation of

future interconnection customers that are not SS Entities for payments for use of such Interconnector-funded JPP Interconnection Facilities (the one switch and one-half (1/2) breaker) shall be included as binding obligations in any such future interconnection agreements between ANPP Switchyard Participants and any such future interconnector(s). Failure to make such payments shall constitute a default under such interconnection agreements and as such will be resolved pursuant to the applicable default provisions of such interconnection agreements;

- 6.1.3. The nonexclusive use of and benefit from the HAA;
- 6.1.4. The nonexclusive use of the Common Bus Arrangement;
- 6.1.5. The right to transfer, assign, or otherwise dispose of its rights under this Agreement as provided in Article 20 of this Agreement;
- 6.1.6. The right to retain all proceeds derived from any use by it permitted under this Section 6.1;
- 6.1.7. The rights and obligations with respect to taxes as provided in Article 15 of this Agreement; and
- 6.1.8. A non-exclusive easement for the Interconnector's Interconnection Facilities as provided in Section 6.2 of this Agreement.

6.2. Easement:

- 6.2.1. Operator shall grant to Interconnector, its successors and assigns, subject to the terms and conditions of this Agreement, including, without limitation, any provisions relating to relocation or termination, a non-exclusive easement (the "Easement"), substantially in the form attached hereto as Exhibit 6 for the purposes of locating the Interconnector's Interconnection Facilities, and installing, operating, maintaining, repairing and replacing the Interconnector's Interconnection Facilities. Operator makes no representation, warranty or covenant of any kind regarding the title to or priority of such Easement. The Interconnector's Interconnection Facilities shall initially be constructed by Interconnector in the location designated or approved by Operator and shall not be relocated or modified by Interconnector without the consent of Operator. The Interconnector's Interconnection Facilities shall be relocated at the direction of Operator when and as provided in Section 7.4 of this Agreement or any other applicable provision of this Agreement. Subject to the Operator's right to require such relocation, Operator shall not grant rights to any other Hassayampa Interconnector to utilize the Easement Area, as such

term is defined in the Easement, in any manner which would materially interfere with the use thereof by the Interconnector pursuant to this Section 6.2. The Easement shall terminate without further act of any Party upon termination of this Agreement. Upon such termination, Interconnector shall at the request of Operator or any ANPP Switchyard Participant execute and deliver to the requesting Party in recordable form an instrument evidencing such termination.

- 6.2.2. For purposes of installing, operating, maintaining, or repairing the Interconnector's Interconnection Facilities, the Interconnector at all reasonable times shall have, upon advance notice to Operator and subject to Operator's reasonable supervision, the right of ingress and egress on, over, and across the Access Area, as such term is defined in the Easement, necessary to enable the Interconnector to perform such installation, operation, maintenance, or replacement.
- 6.2.3. The Interconnector shall provide to the Operator, upon advance notice at all reasonable times and with reasonable supervision, the right of ingress and egress to the Generating Facility and Interconnector's Interconnection Facilities for any purposes necessary to enable the Operator to perform its duties consistent with Good Utility Practice and Applicable Requirements or to reasonably determine the Interconnector's compliance with this Agreement.
- 6.2.4. Without limiting any other provision of this Agreement pertaining to Applicable Requirements, it is hereby expressly acknowledged and agreed that, while any Party is exercising its rights with respect to the Easement pursuant to this Section 6.2, such Party and its personnel, agents and contractors shall comply with Applicable Requirements.

6.3. Transaction Rights:

- 6.3.1. Subject to the terms and conditions of this Agreement and Applicable Requirements, the Interconnector is hereby granted the right to physically connect its Generating Facility to the Common Bus using the Interconnector's Interconnection Facilities, and the JPP Interconnection Facilities. However, this right does not give the Interconnector the right to inject power and energy into the Common Bus, except and only to the extent that all necessary arrangements for transmission rights and service, including transmission-related mitigation requirements, if any, are in place for the delivery thereof. This Agreement does not grant the Interconnector the right under any circumstances to inject power

and energy into the Common Bus except from the Generating Facility and not in excess of the rated capability thereof.

6.3.2. Nothing in this Agreement shall be deemed either expressly or implicitly to obligate any Party to provide or make available to the Interconnector any transmission services, balancing authority area services, distribution services, or ancillary services for the transport of energy to or from the Generating Facility and the ANPP Switchyard Participants make no representation to Interconnector regarding the availability of such services.

6.3.3. This Agreement provides no obligation for any Party to purchase, sell, transmit, or otherwise provide any other rights, including the right to inject power and energy into the Common Bus, with respect to the power and energy generated by or required for the Generating Facility, other than as provided herein with respect to the Common Bus Arrangement.

6.4. Reimbursement: To the extent not prohibited by Law, any interconnection agreement that permits a Hassayampa Interconnector that (i) is not a party to the Funding Agreement to interconnect to the HAA, or (ii) is a party to the Funding Agreement, but requests an additional connection to the HAA not provided for in the Funding Agreement, shall contain a provision that such Hassayampa Interconnector shall be responsible for and required to pay, within thirty (30) calendar days of the in-service date of the connection described in that interconnection agreement, its Pro Rata Share (calculated with the inclusion of its requested interconnection(s)) of all Construction Costs associated with the development of the HAA and the cost of any Capital Improvements made to the Common Bus for which the other Hassayampa Interconnectors which are parties to the Funding Agreement paid or are responsible to pay under their interconnection agreements. Such a Hassayampa Interconnector making a Pro Rata Share payment shall receive a Pro Rata Share (calculated without the inclusion of such interconnector) of any such payments received. Interconnector acknowledges that the reimbursement described in the prior sentence will be payable to the SS Entity that is a party to the Shared Facilities Responsible Project IA, and Interconnector agrees that payment of such reimbursement pursuant to the Shared Facilities Responsible Project IA satisfies the reimbursement obligation under the prior sentence of this Section 6.4. Interconnector acknowledges and agrees that under no condition shall the ANPP Switchyard Participants be liable for a failure of any SS Entity that is or becomes a party to the Shared Facilities Responsible Project IA to satisfy its obligation to disburse such reimbursement among the other SS Entities. Interconnector acknowledges and agrees that all issues or disputes between Interconnector and the SS Entity that is a party to the Shared Facilities Responsible Project IA regarding distribution of this reimbursement shall be resolved between

Interconnector and the SS Entity that is a party to the Shared Facilities Responsible Project IA only. In the event that a Hassayampa Interconnector incurs costs in association with the accommodation of outages necessary for the initial connection of any future Hassayampa Interconnector that (i) is not a party to the Funding Agreement, or (ii) is a party to the Funding Agreement, but requests an additional connection to the HAA not provided for in the Funding Agreement, the Hassayampa Interconnector shall be entitled to seek reimbursement of such costs from such future Hassayampa Interconnector. Such costs shall be determined in accordance with Good Utility Practice and Applicable Requirements. Each Hassayampa Interconnector shall use reasonable efforts to minimize the costs incurred.

6.4.1. The SS Entities share a single Connection. As a result, the COMMON FACILITIES USE FEE, as calculated in accordance with Exhibit 2, will be assessed only one time pursuant to the Shared Facilities Responsible Project IA, and upon full payment of the COMMON FACILITIES USE FEE by one or more of the SS Entities, no future SS Entity will be assessed the COMMON FACILITIES USE FEE. If the COMMON FACILITIES USE FEE, as calculated in accordance with Exhibit 2, has not been paid in full by one or more of the SS Entities by the In-Service Date, then pursuant to Section 6.4, Interconnector shall pay the remaining unpaid portion of the COMMON FACILITIES USE FEE, as calculated in accordance with Exhibit 2, with payment due in accordance with Section 11.6 of this Agreement.

6.5. During the term of this Agreement, for so long as the ANPP Switchyard Participants are permitted by FERC to operate using the Common Bus Arrangement and do not charge Interconnector a separate charge for transmission services provided within or across the Common Bus, Interconnector agrees that (i) it is not entitled to and will not seek transmission credits associated with costs borne by Interconnector or any other SS Entity in connection with its Pro Rata Share or PV CRR, as applicable, of costs associated with the Common Bus, (ii) it will not seek to have the costs associated with the Common Bus facilities rolled-in to the transmission rates of any ANPP Switchyard Participant, and (iii) it is not entitled to and will not seek any refund or repayment of or any other direct or indirect means of recovering any such costs, except as provided in Section 6.4 herein. However, nothing in the preceding sentence shall affect the requirements and limitations of Section 6.3 of this Agreement.

7. OWNERSHIP:

7.1. The Interconnector's Interconnection Facilities shall be owned by and remain the property of the Interconnector and other SS Entities.

- 7.2. Except as expressly provided in this Agreement and subject to Applicable Requirements, the ANPP Switchyard Participants shall have the right, in their sole discretion, to interconnect with or allow others to interconnect with, operate and maintain in accordance with Good Utility Practice, expand, sell, or otherwise dispose of any portion of the Common Bus as they may deem necessary or appropriate subject to the terms and conditions of this Agreement. Subject to Section 20.2 of this Agreement, nothing in this Agreement shall be deemed to limit, expand or otherwise modify the right of each ANPP Switchyard Participant to sell, assign, transfer or otherwise dispose of all or any part of its interest in the Common Bus in accordance with the ANPP Switchyard Participation Agreement.
- 7.3. Nothing in this Agreement shall interfere with or impair the rights or entitlements under any other agreement of any ANPP Switchyard Participant, any Kyrene Line Owner, and/or any North Gila Line Owner existing as of the date of this Agreement, including use of the Common Bus or the existing electric transmission lines and switchyard facilities connected thereto.
- 7.4. The ANPP Switchyard Participants may modify or relocate the Interconnector's Interconnection Facilities, subject to the prior approval of the E&O Committee, as required (i) to meet Applicable Requirements or enable the operation of the Common Bus in accordance with Good Utility Practice, the costs thereof being Operating Costs payable pursuant to Section 11.2 herein, or (ii) to facilitate future Connections in accordance with Good Utility Practice and Applicable Requirements. To the extent permitted by Law, the costs of future Connections, including the costs of modifications or relocations required to facilitate such Connections, shall be payable solely by the Person requesting such Connection. In the event that the ANPP Switchyard Participants propose to make any such modification or relocation, the Operator will notify the Shared Facilities Manager in advance and provide a reasonable opportunity for consultation. Notwithstanding the foregoing, the Interconnector acknowledges and agrees that the Operator has no obligation under this Agreement to disclose any information which violates either a confidentiality requirement in any ANPP Switchyard Participant's Open Access Transmission Tariff, as provided to the Operator, or any Applicable Requirement.

8. OPERATION OF HASSAYAMPA SWITCHYARD:

8.1. Operator:

- 8.1.1. The Operator shall act in good faith to operate, maintain, and control the Common Bus and JPP Interconnection Facilities (i) in accordance with Good Utility Practice and Applicable Requirements; and (ii) in accordance with the provisions of this Agreement.

- 8.1.2. The Operator shall act in good faith to perform Operating Work for the HAA and the JPP Interconnection Facilities, and budgeted Capital Improvements thereto, in accordance with Good Utility Practice and pursuant to the terms and conditions of this Agreement.
 - 8.1.3. The Operator shall continue to perform its duties and responsibilities pursuant to the ANPP Switchyard Participation Agreement.
 - 8.1.4. The Operator shall initially compute the Hassayampa CRR in the manner set forth in Exhibit 3, HAA COST RESPONSIBILITY RATIO (HAA CRR), hereto, and the PV CRR in the manner set forth in Exhibit 4, PV SWITCHYARD COST RESPONSIBILITY RATIO (PV CRR) hereto. For each change in the number of Connections to the ANPP Switchyard, the Hassayampa CRR and PV CRR shall be recomputed promptly and shall be effective upon the in service date of each such additional Connection. Upon completion of such recomputation, the Operator shall revise Exhibit 3, HAA COST RESPONSIBILITY RATIO (HAA CRR), and Exhibit 4, PV SWITCHYARD COST RESPONSIBILITY RATIO (PV CRR), in accordance with Section 31.5 of this Agreement.
 - 8.1.5. The Operator shall recalculate the Pro Rata Share for the Interconnector collectively with the other SS Entities upon any increase or decrease in the number of Connections in the HAA.
 - 8.1.6. The Operator shall notify the Shared Facilities Manager of any termination notice received from any other Hassayampa Interconnector, as soon as practicable.
- 8.2. Common Bus Arrangement:
- 8.2.1. The Common Bus shall be operated as a Common Bus Arrangement.
 - 8.2.2. There will be no transmission charge or transmission credit associated with service occurring solely within the Common Bus. The absence of a transmission charge shall not be considered a discount for purposes of the ANPP Switchyard Participants' Open Access Transmission Tariff.
 - 8.2.3. Electrical losses in regards to use of the Common Bus Arrangement shall be determined in accordance with Good Utility Practice and allocated between the HAA and the PV Switchyard by the E&O Committee.

8.3. Scheduled Outages: The Parties acknowledge that it may be necessary from time to time for the Operator to de-energize the JPP Interconnection Facilities and/or certain other Connections which now exist or may exist in the future in order to, among other things: (i) perform Operating Work, (ii) install other Connections, and (iii) install any Capital Improvements, modifications, upgrades, or additions required to accommodate a request for interconnection by any Non-Common Bus Interconnector. The Operator, in accordance with Good Utility Practice and Applicable Requirements, shall act in good faith to coordinate the timing and minimize the duration of any scheduled outage of such Interconnector's Interconnection Facilities and/or certain other Connections with the Interconnector, any ANPP Switchyard Participants, or any other Hassayampa Interconnectors that may be affected by such outage. In the event that a scheduled outage will affect only the Interconnector (for example, if the sole purpose of the outage is to perform work on the JPP Interconnection Facilities), then Operator shall notify the Shared Facilities Manager of the Operator's intention to perform such work, including an estimate of the duration of the outage, and, if the Shared Facilities Manager responds on a timely basis, shall schedule such outage at a time acceptable to the Shared Facilities Manager in the Operator's reasonable discretion. If the restoration of the JPP Interconnection Facilities and/or certain other Connections might reasonably be expected to extend beyond the time scheduled by the Operator for the work, the Operator, acting in good faith, shall notify the Shared Facilities Manager and any ANPP Switchyard Participant that may be affected by such outage regarding the reason for the delay and when the Operator expects to restore the JPP Interconnection Facilities and/or certain other Connections to service.

8.4. Operating Emergency:

8.4.1. In the event of an Operating Emergency, the Operator, in accordance with Good Utility Practice and Applicable Requirements, shall act in good faith to take any and all steps reasonably necessary to terminate and, pending such termination and to the extent not inconsistent therewith, mitigate the Operating Emergency.

8.4.2. As soon as practicable following the occurrence of an Operating Emergency, the Operator shall advise the Interconnector's scheduling representative, or designee, of the nature and expected duration of the Operating Emergency and the steps taken or planned to be taken for the termination or mitigation of such Operating Emergency.

8.4.3. In the event that the Operating Emergency results in the destruction of or damage to the Common Bus or the JPP Interconnection Facilities, or impairs the operation of the Common Bus or the JPP

Interconnection Facilities, Operator, in consultation with the ANPP Switchyard Participants, as necessary, shall expend in accordance with Good Utility Practice and Applicable Requirements, any funds necessary or appropriate to repair, restore or reconstruct the damaged or destroyed facilities to the extent necessary to restore the operation of the Common Bus or the JPP Interconnection Facilities to substantially the same general condition as existed prior to the Operating Emergency. Subject to Section 16.2 herein, the Interconnector shall be obligated to pay its Pro Rata Share or PV CRR, as applicable, of the costs of such repair, restoration or reconstruction as Operating Costs in accordance with Section 11.2 herein. In the event that the Operator or any ANPP Switchyard Participant recovers any sums from any third Person in connection with such destruction or damage, the Operator or ANPP Switchyard Participant shall apply such sums to the repair, restoration, or reconstruction work undertaken pursuant to this Section 8.4.3, provided that if the Interconnector has already reimbursed the Operator for such work, the Operator or ANPP Switchyard Participant, as applicable, shall refund to or credit the Interconnector in an amount equal to its Pro Rata Share or PV CRR, as applicable, of the sum recovered. Any reimbursement described in this Section 8.4.3 will be payable to the SS Entity that is a party to the Shared Facilities Responsible Project IA. Interconnector acknowledges and agrees that payment in full of such reimbursement pursuant to the Shared Facilities Responsible Project IA fully satisfies the reimbursement obligation under this Section 8.4.3. Under no condition shall the ANPP Switchyard Participants be liable for a failure of any SS Entity that is or becomes a party to the Shared Facilities Responsible Project IA to satisfy its obligation to disburse such reimbursement among the other SS Entities. Interconnector acknowledges and agrees that all issues or disputes between Interconnector and the SS Entity that is a party to the Shared Facilities Responsible Project IA regarding distribution of this reimbursement shall be resolved between Interconnector and the SS Entity that is a party to the Shared Facilities Responsible Project IA only.

- 8.4.4. Following the occurrence of an Operating Emergency, the Operator shall be authorized to proceed immediately or at any time thereafter, in its discretion, with any action necessary or appropriate to terminate such Operating Emergency in accordance with Good Utility Practice and Applicable Requirements.
- 8.4.5. Following the termination of any Operating Emergency, the Operator shall submit to the Parties a report containing a summary of the costs incurred and expenditures made in connection with the

mitigation and termination of such Operating Emergency and such other information as may be reasonably required by the Parties.

9. OPERATION:

9.1. Interconnector Obligations:

- 9.1.1. Operation of Facilities: The Interconnector shall operate, maintain, and control the Generating Facility and the Interconnector's Interconnection Facilities (i) in accordance with Good Utility Practice and Applicable Requirements, to the extent applicable to the Interconnector; and (ii) in accordance with the provisions of this Agreement. The Interconnector shall cooperate with and timely provide to the Operator all information as the Operator may, acting in good faith, request in order for the Operator to comply with Applicable Requirements.
- 9.1.2. Material Alterations: Interconnector shall give Operator advance notice of any Material Alteration, which Interconnector intends to make. For purposes of this Section 9.1.2, "Material Alteration" means any physical change to the Generating Facility or the Interconnector's Interconnection Facilities which (i) deviates from any of the applicable information set forth in Appendix C, INTERCONNECTION DETAILS, attached hereto (which may require amendment pursuant to Section 31.5 of this Agreement), (ii) fails to conform with any other express requirement of this Agreement, (iii) fails to comply with any Applicable Requirement, (iv) affects the operation of the Common Bus or the electrical systems connected thereto, or (v) requires Mitigation. Interconnector shall give notice of such Material Alteration sufficiently prior to the date when it is planned to be placed in service to allow Operator a reasonable opportunity, using Good Utility Practice, to evaluate the potential impacts thereof, identify any appropriate Mitigation associated therewith and, to the extent such Mitigation affects the Common Bus, complete such Mitigation, all at the expense of Interconnector. If Operator at any time becomes aware of a Material Alteration, whether or not Interconnector has given timely notice thereof, Operator, acting in good faith and consistently with Good Utility Practice, may require Interconnector to operate in a manner which does not violate any of clauses (ii), (iii) or (iv) of this Section 9.1.2, may require Interconnector to perform or cause to be performed Mitigation resulting from such Material Alteration or, if such Mitigation affects the Common Bus, may perform such Mitigation at Interconnector's expense, and may impose specific requirements for the foregoing purposes. If any Material Alteration, in the sole judgment of the Operator, acting in good faith, may endanger life or property or may

pose a threat to system reliability, Operator shall proceed immediately or at any time thereafter with any action necessary or appropriate to terminate such endangerment or threat to system reliability. If any Material Alteration causes an Operating Emergency, Operator shall proceed in accordance with Section 8.4 to the extent applicable and consistent with the provisions of this Section 9.1. Nothing in this Section 9.1 is intended to relieve Interconnector from its obligations under any other provisions of this Agreement or to limit any other right or remedy of Operator or any Party as a result of a breach or default by Interconnector.

- 9.2. Balancing Authority Area Services: The Interconnector shall provide an executed copy of its balancing authority area agreement, if applicable, acceptable to the Operator in conformance with Good Utility Practice, prior to the proposed In-Service Date.
- 9.3. Switching and Tagging Rules: The Interconnector shall abide by the Operator's switching and tagging rules for obtaining clearances for work or for switching operations on equipment located outside the HAA up to the first point of disconnection. Operator shall provide training on such procedures for the Interconnector, if requested.
- 9.4. Reactive Power Standards: The Generating Facility power factor design limitation minimum requirement shall be a reactive power capability of sufficient MVAR that would result in a composite power delivery at the HAA at a power factor between 0.95 leading and 0.95 lagging at rated capacity. Under normal operating conditions, the Interconnector shall operate the Generating Facility to maintain a voltage at the HAA as prescribed by the Operator within the Generating Facility's power factor design limitations. In the event that, under normal operating conditions the Generating Facility is unable to consistently maintain a reactive power capability sufficient to maintain a composite power delivery at the HAA at a power factor between 0.95 leading and 0.95 lagging, the Interconnector shall take necessary steps to meet such standards, including but not limited to the installation of static and/or dynamic reactive power compensating devices. Should the Operator determine, in its sole discretion and in accordance with Good Utility Practice, that operation of the Generating Facility at power factors not in compliance with this Agreement may compromise the reliability or integrity of, or would materially adversely affect, the Common Bus, the Operator may order the Interconnector to disconnect its Generating Facility until such time as required remedies are made.
- 9.5. Operating Expenses: As between Interconnector and the ANPP Switchyard Participants, the Interconnector shall be solely responsible for all Generating Facility and Interconnector's Interconnection Facilities operating expenses.

9.6. System Protection:

9.6.1. The Interconnector shall, at its expense, install, maintain, and operate system protection facilities, including such protective and regulating devices as are required by Good Utility Practice and Applicable Requirements or as are otherwise reasonably necessary to protect personnel and equipment and to minimize adverse effects to the Common Bus and the JPP Interconnection Facilities, ANPP Switchyard Participants, or any other Person interconnected to the Common Bus, arising from operation of the Generating Facility. Any such protective or regulating devices that may be required on the ANPP Switchyard Participants' facilities in connection with the operation of the Generating Facility shall be installed at the Interconnector's expense.

9.6.2. In compliance with Good Utility Practice and Applicable Requirements, Interconnector shall provide, install, own, and maintain relays, circuit breakers, and all other devices necessary to promptly remove any condition of or affecting the Generating Facility that causes or contributes to any short circuit occurring on the Common Bus and the JPP Interconnection Facilities. Interconnector shall be responsible for protection of the Generating Facility and the Interconnector's other equipment from such conditions as negative sequence currents, over- or under-frequency, sudden load rejection, over- or under-voltage, and generator loss-of-field. Interconnector shall be solely responsible for provisions to disconnect the Generating Facility and Interconnector's other equipment when any of the above-described disturbances occur.

9.7. Interconnector agrees that the Commercial Operation Date for the 150 MW relating to the Generation Facility shall be in substantial accordance with the dates set forth in Appendix B MILESTONES, which dates may be revised by the Operator from time to time in accordance with Section 31.5, subject to approval by the E&O Committee, contingent upon Interconnector's satisfactory showing that an extension is justified due to unforeseen delays in engineering, permitting and/or construction of the Generating Facility or for any other reason permitted under the ANPP High Voltage Switchyard Large Generator Interconnection Procedures (LGIP), as may be revised from time to time, such approval not to be unreasonably withheld.

9.8. The Parties further agree that, Article 18, Uncontrollable Forces, expressly does not include economic conditions that render a Party's performance under this Agreement unprofitable or otherwise uneconomic (including, without limitation, Interconnector's ability to procure construction materials

or to enter into power purchase agreements for the output, at prices consistent with Interconnector's business plans).

10. SCHEDULING AND DISPATCHING:

10.1. The Operator shall develop, prior to the Interconnection Facilities In-Service Date and may amend from time to time, scheduling and dispatching procedures in accordance with Good Utility Practice and Applicable Requirements, with respect to, among other things, congestion management, transmission losses, scheduling, and dispatching for transactions to be conducted into or out of the Common Bus. The Operator shall have the authority to implement and enforce, and the Interconnector shall comply with, any such procedures.

10.2. The Interconnector desiring to schedule power and energy into or out of the Common Bus shall first make all necessary arrangements for transmission rights and service for such power and energy and then shall submit, or make arrangements to submit, hourly schedules and any changes thereto to the Operator's schedulers and/or dispatchers in accordance with the scheduling and dispatching procedures established pursuant to Article 10.1 of this Agreement. Notwithstanding the notice requirements of Article 27 of this Agreement, if the Interconnector does not comply with the established scheduling and dispatching procedures, the Operator shall inform the Interconnector and the other Parties of such failure, and shall not be obligated to accept the schedule of such Interconnector until such scheduling and dispatching procedures have been complied with and requirements have been met.

10.3. Interconnector, at its sole expense, shall provide revenue quality metering equipment, or such other equipment as deemed necessary by the Operator in accordance with Good Utility Practice and Applicable Requirements, to meet its metering and telemetry requirements for generator unit output and any back feed or auxiliary load requirements of the Generating Facility. The installation, testing, and maintenance of such equipment shall be coordinated between the Operator and the Interconnector.

11. COST RESPONSIBILITY:

11.1. Installation Costs: JPP Interconnection Facilities as described in Appendix A, INTERCONNECTION FACILITIES, shall be designed, procured, constructed and installed at the sole expense of the SS Entities.

11.2. Operating Costs: Interconnector shall be responsible for the portion of the following Operating Costs allocated to the SS Entities pursuant to this Section 11.2; provided, however, that the SS Entity that is a party to the Shared Facilities Responsible Project IA will be responsible for payment of such allocation of Operating Costs pursuant to the Shared Facilities Responsible Project IA. Nothing contained in the previous sentence relieves Interconnector of its obligations under this Section 11.2. Payment of such allocation of Operating Costs pursuant to the Shared Facilities Responsible Project IA satisfies Interconnector's payment obligations under this Section 11.2. In the event of non-payment of such allocation of Operating Costs by the SS Entity that is a party to the Shared Facilities Responsible Project IA, Interconnector shall pay or cause to be paid such allocation of Operating Costs according to the terms of Section 12.3.1 of this Agreement.

11.2.1. Interconnection Facilities and Hassayampa Switchyard: The Interconnector's Pro Rata Share of all Operating Costs pertaining to the HAA, Hassayampa Interconnection Facilities, and the JPP Interconnection Facilities (including but not limited to Operator's overhead expenses, applicable labor loading charges, and administrative and general expenses). For clarification, costs for Capital Improvements to the JPP Interconnection Facilities, which Capital Improvements are requested by Interconnector, shall be the sole responsibility of the Interconnector; and

11.2.2. Palo Verde Switchyard: The PV CRR of all Operating Costs pertaining to the Palo Verde Switchyard (including but not limited to overhead expenses, applicable labor loading charges, and administrative and general expenses) as defined and provided in the ANPP Switchyard Participation Agreement.

11.3. Requests for Mitigation: In the event that the Interconnector, Operator or any ANPP Switchyard Participant receives from any Person a written request for Mitigation or the costs therefor or any other written claim that reasonably may result in a request for Mitigation or the costs thereof, the Party receiving the request shall provide prompt notice thereof, in conformance with Article 27 of this Agreement, to all of the Hassayampa Interconnectors, Operator, ANPP Switchyard Participants and the E&O Committee. The E&O Committee shall review the notice and, acting in good faith, promptly determine preliminarily (i) if the notice involves a request for Mitigation or the costs thereof or a claim that reasonably may result in such a request (in either case, a "Mitigation Request"), (ii) which Hassayampa Interconnectors may be responsible for the requested Mitigation in accordance with Good Utility Practice, and (iii) if the notice involves any claim other than a Mitigation Request that may be made against one or more ANPP Switchyard Participants. Upon making such preliminary determination, the E&O Committee shall issue a notice of such preliminary

determination to all of the Hassayampa Interconnectors, Operator and ANPP Switchyard Participants. If Interconnector is identified in such a notice from the E&O Committee as potentially responsible for satisfying the Mitigation Request, Interconnector shall, alone or jointly with other similarly identified Hassayampa Interconnectors, respond to the Person making the Mitigation Request and either contest the Mitigation Request or arrange for completion of, or payment for, the requested Mitigation, as applicable, keeping the E&O Committee informed of such activities on a reasonable ongoing basis. If such E&O Committee notice also identifies any claim other than a Mitigation Request against one or more ANPP Switchyard Participants, Interconnector shall act jointly in good faith with such ANPP Switchyard Participant(s) in responding to the Person making such claim and the Mitigation Request. If subsequent to issuance of the E&O Committee notice, the E&O Committee, based on further study in conformance with Good Utility Practice, determines that it needs to modify the preliminary determination described above, the E&O Committee shall issue a new notice in the same manner as its initial notice, and Interconnector shall respond in the same manner as is required upon receipt of any initial notice. In the event that the Hassayampa Interconnectors agree to satisfy the Mitigation Request and, as a result, work is required within the Common Bus or the property of any ANPP Switchyard Participant, the Operator or ANPP Switchyard Participant(s), as applicable, shall act in good faith to perform the work in accordance with Good Utility Practice, provided that the Interconnector pays for its share of the costs thereof, as determined by the E&O Committee consistent with this Section 11.3. The limitations and disclaimers of Section 17.2 of this Agreement notwithstanding, the Interconnector shall defend, indemnify and hold harmless Operator, the ANPP Switchyard Participants, and any other Hassayampa Interconnector which has entered into an interconnection agreement containing a substantially similar indemnification obligation for, from and against the Interconnector's share, as determined by the E&O Committee consistent with Section 11.3 herein, of any Mitigation costs paid or incurred by any Person.

- 11.4. Should a future interconnector elect to interconnect in the Bay 4 west position, the Interconnector shall be reimbursed by that interconnector for the full originally installed value of switch 949 and for one-half the originally installed value of breaker 945 (as shown in Appendix C, Figure 4 HASSAYAMPA). Interconnector acknowledges that the reimbursement described in the prior sentence will be payable to the SS Entity that is a party to the Shared Facilities Responsible Project IA, and Interconnector acknowledges and agrees that payment of such reimbursement pursuant to the Shared Facilities Responsible Project IA satisfies the reimbursement obligation under the prior sentence of this Section 11.4. Under no condition shall the ANPP Switchyard Participants be liable for a failure of any SS Entity that is or becomes a party to the Shared Facilities Responsible Project IA to satisfy its obligation to disburse such reimbursement among

the other SS Entities. Interconnector acknowledges and agrees that all issues or disputes between Interconnector and the SS Entity that is a party to the Shared Facilities Responsible Project IA regarding distribution of this reimbursement shall be resolved between Interconnector and the SS Entity that is a party to the Shared Facilities Responsible Project IA only.

11.5. Interconnector has entered into an agreement with the SS Entities to share the interconnection facilities and termination position in the HAA. Interconnector acknowledges and agrees that any such agreement(s) do not relieve Interconnector of its obligations to ensure all payments due under this Agreement are made timely and in full. Under no condition shall the ANPP Switchyard Participants be liable for a failure of any SS Entity to pay any amounts owed to the Interconnector under any such separate agreement(s). Interconnector acknowledges and agrees that all issues or disputes between Interconnector and the SS Entities, arising under any such separate agreement(s), of any nature, shall be resolved among Interconnector and the other SS Entities only. Interconnector's failure to make any payment owed under this Agreement shall constitute a default and as such will be resolved pursuant to the applicable default provisions of this Agreement.

11.6. In accordance with Article 12 and the specific payment provisions of each Exhibit to this Agreement, on or before the In-Service Date, the Interconnector shall make, cause to be made, or provide evidence of payment of the following amounts due to the Operator: 1) any remaining unpaid portion of the Common Facilities Use Fee as described in Section 6.4.1, 2) the Mitigation Facility Fee payment in accordance with the formulas set forth in Exhibit 8 to this Agreement, and 3) all costs specific to the interconnection of the Generating Facility as set forth in Exhibit 9 to this Agreement.

12. BILLING AND PAYMENT:

12.1. Preparation and Submission of Budgets for Operating Costs: The Operator shall prepare an initial budget for Operating Costs for the period commencing with the Effective Date to the end of the calendar year. The Operator shall prepare an annual budget for Operating Cost for each calendar year thereafter. Operator shall have the right to amend any such budget from time to time or change to a non-calendar year and shall provide notice to the Shared Facilities Manager of any such change. For purposes of this Article 12, the term "budget" shall include any such amended budget. Each budget shall show the estimated monthly expenses and costs allocated to the Interconnector pursuant to this Agreement. The Operator shall submit such budgets to the E&O Committee concurrently with its submittal of other budgets prepared pursuant to the ANPP Switchyard Participation Agreement.

12.2. Budget Approvals: The budget for the estimated Operating Cost (excluding costs for Capital Improvements to JPP Interconnection Facilities that are not necessary to prevent impairment of the operation of the Common Bus) and any other expenses and costs allocated to the Interconnector pursuant to this Agreement shall be subject to the approval of the E&O Committee. Submittal of such budget to the Shared Facilities Manager shall be for informational purposes only. The budget for the estimated costs of Capital Improvements to the JPP Interconnection Facilities for which the Interconnector is responsible under this Agreement and that are not necessary to prevent impairment of the operation of the Common Bus shall be subject to the approval by the Shared Facilities Manager, which approval shall not be unreasonably withheld.

12.3. Invoices:

12.3.1. The Operator shall invoice the Interconnector, as provided in Section 12.3.2 of this Agreement, on a monthly basis for its applicable share of estimated monthly Operating Costs; provided, that adjustments for actual Operating Costs for such month shall be reflected in the invoice for the calendar month which follows the date of determination of such actual Operating Costs. As described in Section 11.2, the SS Entity that is a party to the Shared Facilities Responsible Project IA will be responsible for payment of such allocation of Operating Costs, and Interconnector agrees that delivery of an invoice for such allocation of Operating Costs pursuant to the Shared Facilities Responsible Project IA satisfies the invoicing obligation under Article 12 of this Agreement. Notwithstanding the foregoing, the SS Entities with generating facilities that have achieved their in-service dates are jointly and severally liable for the portion of the Operating Costs that are allocated to the Connection shared by the SS Entities. Nothing contained in this Section 12.3.1 relieves Interconnector of its obligations under this Section 12.3.1. Payment of such allocation of Operating Costs pursuant to the Shared Facilities Responsible Project IA satisfies Interconnector's payment obligations under this Section 12.3.1. If the SS Entity that is a party to the Shared Facilities Responsible Project IA fails to pay in full such allocated share of the Operating Costs when due under the Shared Facilities Responsible Project IA, then Operator will send notice of any such non-payment to the Shared Facilities Manager. Interconnector and/or one or more of the other SS Entities shall pay the past-due portion of the Operating Costs that are allocated to the Connection shared by the SS Entities within thirty (30) days after Shared Facilities Manager's receipt of such notice. Failure to pay the past-due amounts by the deadline set forth in the preceding sentence, if such failure is not cured within the timeframes under the default provisions in Section 22.1 of this Agreement, may subject the JPP

Interconnection Facilities to disconnection pursuant to Section 22.2 of this Agreement.

- 12.3.2. Invoices prepared by the Operator shall be mailed, or delivered by electronic means, on or before the twenty-fifth (25th) calendar day (the "Mailed Date") of the month two (2) months prior to the month in which the Operator anticipates that the costs specified in the invoices will be incurred and payment shall be due and payable by the thirtieth (30th) calendar day of the month prior to the month in which such costs are anticipated to be incurred (or when payment is due and payable in February, by the twenty-eighth calendar day of that month); provided, however, that the payment due date will be extended by one (1) day for each day beyond the Mailed Date that the Operator mailed, or electronically delivered, the invoice. Such invoices shall be addressed to the Interconnector at the addresses below, which addresses may from time to time be amended by Interconnector through a written notice from Interconnector to Operator:

Sun Streams 2, LLC
Attention: First Solar Accounts Payable
E-mail: fseinvoices@firstsolar.com

With a copy to:
Sun Streams 2, LLC
Attention: Melanie Falls, Senior Manager, Project
Development
135 Main Street, 6th Floor
San Francisco, CA 94105
E-Mail: melanie.falls@firstsolar.com

- 12.3.3. In the event that the Operator determines, at any time, that any prior invoice was not accurate or complete, Operator may adjust the amount of the current or any succeeding invoice to correct such inaccuracy.

- 12.3.4. Upon request, Operator will make available to Interconnector documentation reasonably supporting any invoice rendered to Interconnector within the past twelve (12) calendar months.

12.4. Payments:

- 12.4.1. The Interconnector shall pay or cause to be paid (in funds immediately available as of the due date thereof) each invoice on or before the due date as specified in Section 12.3.2 of this Agreement.

- 12.4.2. All payments, including late payment charges paid pursuant to Section 12.10 herein, received by the Operator pursuant to this Article 12 shall be placed in a demand deposit account from which the Operator shall make disbursements for expenditures and obligations incurred by it in the performance of Operating Work. Interest received, if any, shall be applied toward Operating Costs.
- 12.4.3. Payment shall be considered made on the date payment is received by the Operator.
- 12.5. Minimum Balance of Account: The Operator shall establish a reasonable minimum balance for the operating account from which the Operator will make disbursements for expenditures and obligations incurred by it pursuant to this Agreement. Such minimum balance shall be reasonably calculated to provide adequate liquidity for normal operations and to allow adequate time for notices and the exercise of remedies against any of the Hassayampa Interconnectors, and may be revised by the Operator from time to time to achieve such purposes. The Operator shall give Interconnector notice of the amount of such minimum balance and any change thereto. The Interconnector shall be responsible for its Pro Rata Share or PV CRR, as applicable, of such minimum balance as in effect from time to time. Interconnector acknowledges that the notice of the minimum balance and any change thereto will be provided to the SS Entity that is a party to the Shared Facilities Responsible Project IA, and Interconnector agrees that provision of such notice pursuant to the Shared Facilities Responsible Project IA satisfies the notice obligation under this Section 12.5. The SS Entity that is a party to the Shared Facilities Responsible Project IA will be responsible for such Pro Rata Share or PV CRR, as applicable, of such minimum balance as in effect from time to time. Nothing contained in the previous sentence relieves Interconnector of its obligations under this Section 12.5. Payment of such Pro Rata Share or PV CRR, as applicable, of such minimum balance pursuant to the Shared Facilities Responsible Project IA satisfies Interconnector's payment obligations under this Section 12.5. If the SS Entity that is a party to the Shared Facilities Responsible Project IA fails to pay in full such Pro Rata Share or PV CRR, as applicable, when due under the Shared Facilities Responsible Project IA, then Operator will send notice of any such non-payment to the Shared Facilities Manager. Interconnector and/or one or more of the other SS Entities shall pay the past-due portion of such Pro Rata Share or PV CRR, as applicable, within thirty (30) days after Shared Facilities Manager's receipt of such notice. Failure to pay the past-due amounts by the deadline set forth in the preceding sentence, if such failure is not cured within the timeframes under the default provisions of this Agreement, may subject the

JPP Interconnection Facilities to disconnection pursuant to Article 22 of this Agreement.

- 12.6. Advancement of Funds: Nothing contained in this Agreement shall require the Operator or the ANPP Switchyard Participants to advance their own funds on behalf of the Interconnector.
- 12.7. Creditworthiness: At any time during the term of this Agreement, Operator, acting in good faith, may require the Interconnector to provide and maintain in effect a letter of credit or other form of security acceptable to the Operator to meet the Interconnector's responsibilities and obligations. In any instance where facilities to be built require the Operator to incur costs, Operator will not be obligated to incur any costs until the Interconnector has provided Operator with a letter of credit or other form of security acceptable to the Operator in the amount of such costs.
- 12.8. Cost Allocation: In cases where the allocation of a cost item is to be made between Operating Work and other work, or between Operating Costs and other costs, such allocation shall be made on a fair and equitable basis as reasonably determined by the Operator consistent with the terms of this Agreement.
- 12.9. Disputed Charges: If Interconnector disputes any portion of an amount specified in an invoice delivered to Interconnector under this Agreement, it shall make the total payment specified in said invoice without offset, abatement, or reduction of any kind. If it is determined that an overpayment has been made on or behalf of Interconnector, the amount determined to be in excess shall be returned to the Interconnector.
- 12.10. Late Payment Charge: Invoiced amounts not received by the Operator on or before the due date specified herein shall accrue interest in accordance with the provisions of 18 CFR Section 35.19a (a) (2) (iii), prorated on a daily basis from the due date to the day such unpaid amount is paid in full.

13. COORDINATION AND EXCHANGE OF INFORMATION:

- 13.1. Authorized Representative: The Operator, by written notice to Interconnector, shall designate one or more Authorized Representatives authorized to act on its behalf with respect to technical and operational matters related to this Agreement. The Interconnector, by written notice to Operator, shall designate one or more Authorized Representatives authorized to act on its behalf in relation to this Agreement; provided, however, that the Interconnector hereby designates the Shared Facilities Manager as its Authorized Representative authorized to act on its behalf with respect to technical and operational matters related to the shared Interconnector's Interconnection Facilities under this Agreement. The

Interconnector or Operator may change the designation of its Authorized Representative(s) in accordance with the provisions described in Article 27.

- 13.2. E&O Committee Meetings: As a means of permitting the Interconnector to participate in the coordination and exchange of information on a prompt and orderly basis in connection with matters under this Agreement, the Interconnector shall be entitled to have one (1) non-voting representative attend any meeting of the E&O Committee, unless said E&O Committee, acting in good faith, elects to go into executive session for any reason. Operator shall provide timely notification of such E&O Committee meetings to the Interconnector's Authorized Representative.
14. DISPOSITION OF FACILITIES:

Upon termination of this Agreement pursuant to Section 22.3 herein, to the extent that none of the other SS Entities other than Interconnector are utilizing the JPP Interconnection Facilities and/or the Interconnector's Interconnection Facilities at such time, Operator shall have the option either to: (i) retain the JPP Interconnection Facilities and/or the Interconnector's Interconnection Facilities, and pay to Interconnector the Net Salvage Value thereof, or (ii) remove or cause to be removed the JPP Interconnection Facilities and/or the Interconnector's Interconnection Facilities, deliver or cause to be delivered the salvageable material and equipment of such facilities to Interconnector, repair or cause to be repaired any damage to the HAA caused by such removal, and restore or cause to be restored the site to a clean and neat condition. For purposes of the foregoing, the term "Net Salvage Value" shall mean the fair market value of any salvageable material and equipment that would have been delivered to the Interconnector if the Operator had elected to remove the JPP Interconnection Facilities and/or the Interconnector's Interconnection Facilities, minus all costs and expenses that would have been incurred in removing such facilities, repairing any damage to the HAA, and restoring the site to a clean and neat condition. In the event Operator removes the JPP Interconnection Facilities and/or the Interconnector's Interconnection Facilities, pursuant to this Article 14, Interconnector shall reimburse Operator for the costs of such removal, disposition, repair, and restoration. Such reimbursement shall be paid to Operator on the basis of invoices submitted by Operator to Interconnector pursuant to Section 12.3 hereof, and Operator may require security for such costs in accordance with Section 12.7 before commencing any work. If this Agreement is terminated for any reason other than pursuant to Section 22.3 herein, to the extent that none of the SS Entities other than Interconnector are utilizing the JPP Interconnection Facilities and/or the Interconnector's Interconnection Facilities at such time, Operator shall proceed under clause (ii) above, unless Interconnector fails to provide security in accordance with Section 12.7 within thirty (30) calendar days after Operator's request therefor.

15. TAXES:

- 15.1. Interconnector Payments Not Taxable: The Parties intend that all payments or property transfers made by the Interconnector to ANPP Switchyard Participants for the installation of JPP Interconnection Facilities shall be non-taxable, either as contributions to capital, or as an advance, in accordance with the Internal Revenue Code and any applicable state income tax laws and shall not be taxable as contributions in aid of construction or otherwise under the Internal Revenue Code and any applicable state income tax laws, including any applicable laws for ANPP Switchyard Participants which are municipal entities.
- 15.2. Representations and Covenants: In accordance with IRS Notice 2001-82 and IRS Notice 88-129, Interconnector represents and covenants that (i) ownership of the electricity generated at the Generating Facility will pass to another party prior to the transmission of the electricity on the Transmission System; (ii) for income tax purposes, the amount of any payments and the cost of any property transferred to the ANPP Switchyard Participants for JPP Interconnection Facilities will be capitalized by Interconnector as an intangible asset and recovered using the straight-line method over a useful life of twenty (20) years, and (iii) any portion of JPP Interconnection Facilities that is a "dual-use intertie," within the meaning of IRS Notice 88-129, is reasonably expected to carry only a de minimis amount of electricity in the direction of the Generating Facility. For this purpose, "de minimis" means no more than 5 percent of the total power flows in both directions, calculated in accordance with the "5 percent test" set forth in IRS Notice 88-129. This is not intended to be an exclusive list of the relevant conditions that must be met to conform to IRS requirements for non-taxable treatment.

At ANPP Switchyard Participants' request, Interconnector shall provide ANPP Switchyard Participants with a report from an independent engineer confirming its representation in clause (iii), above. ANPP Switchyard Participants represent and covenant that that the cost of JPP Interconnection Facilities paid for by Interconnector will have no net effect on the base upon which rates are determined.

- 15.3. Indemnification for the Cost Consequences of Current Tax Liability Imposed Upon the ANPP Switchyard Participants: Notwithstanding Section 15.1 Interconnector shall protect, indemnify and hold harmless ANPP Switchyard Participants from the cost consequences of any current tax liability imposed against ANPP Switchyard Participants as the result of payments or property transfers made by Interconnector, or by any party on its behalf, to ANPP Switchyard Participants under this Agreement for JPP Interconnection Facilities, as well as any interest and penalties, other than interest and penalties attributable to any delay caused by ANPP Switchyard Participants.

ANPP Switchyard Participants shall not include a gross-up for the cost consequences of any current tax liability in the amounts it charges Interconnector under this Agreement unless (i) ANPP Switchyard Participants have determined, in good faith, that the payments or property transfers made by Interconnector to ANPP Switchyard Participants should be reported as income subject to taxation or (ii) any Governmental Authority directs ANPP Switchyard Participants to report payments or property as income subject to taxation; provided, however, that ANPP Switchyard Participants may require Interconnector to provide security for JPP Interconnection Facilities, in a form reasonably acceptable to ANPP Switchyard Participants (such as a parental guarantee or a letter of credit), in an amount equal to the cost consequences of any current tax liability under this Article 15. Interconnector shall reimburse ANPP Switchyard Participants for such costs on a fully grossed-up basis, in accordance with Section 15.4, within thirty (30) calendar days of receiving written notification from Operator of the amount due, including detail about how the amount was calculated.

The indemnification obligation shall terminate at the earlier of (1) the expiration of the ten year testing period and the applicable statute of limitation, as it may be extended by ANPP Switchyard Participants upon request of the IRS, to keep these years open for audit or adjustment, or (2) the occurrence of a subsequent taxable event and the payment of any related indemnification obligations as contemplated by this Article 15.

- 15.4. Tax Gross-Up Amount: Interconnector's liability for the cost consequences of any current tax liability under this Article 15 shall be calculated on a fully grossed-up basis. Except as may otherwise be agreed to by the parties, this means that Interconnector will pay ANPP Switchyard Participants, in addition to the amount paid for the JPP Interconnection Facilities, an amount equal to (1) the current taxes imposed on ANPP Switchyard Participants ("Current Taxes") on the excess of (a) the gross income realized by ANPP Switchyard Participants as a result of payments or property transfers made by Interconnector to ANPP Switchyard Participants under this Agreement (without regard to any payments under this Article 15) (the "Gross Income Amount") over (b) the present value of future tax deductions for depreciation that will be available as a result of such payments or property transfers (the "Present Value Depreciation Amount"), plus (2) an additional amount sufficient to permit ANPP Switchyard Participants to receive and retain, after the payment of all Current Taxes, an amount equal to the net amount described in clause (1).

For this purpose, (i) Current Taxes shall be computed based on ANPP Switchyard Participants' composite federal and state tax rates at the time the payments or property transfers are received and ANPP Switchyard Participants will be treated as being subject to tax at the highest marginal rates in effect at that time (the "Current Tax Rate"), and (ii) the Present

Value Depreciation Amount shall be computed by discounting ANPP Switchyard Participants' anticipated tax depreciation deductions as a result of such payments or property transfers by ANPP Switchyard Participants' current weighted average cost of capital. Thus, the formula for calculating Interconnector's liability to ANPP Switchyard Participants pursuant to this Article 15 can be expressed as follows: $(\text{Current Tax Rate} \times (\text{Gross Income Amount} - \text{Present Value of Tax Depreciation})) / (1 - \text{Current Tax Rate})$.

- 15.5. Private Letter Ruling or Change or Clarification of Law: At Interconnector's request and expense, Operator shall file with the IRS a request for a private letter ruling as to whether any property transferred or sums paid, or to be paid, by Interconnector to ANPP Switchyard Participants under this Agreement are subject to federal income taxation. Interconnector will prepare the initial draft of the request for a private letter ruling, and will certify under penalties of perjury that all facts represented in such request are true and accurate to the best of the Interconnector's knowledge.

Operator and Interconnector shall cooperate in good faith with respect to the submission of such request. Operator shall keep Interconnector fully informed of the status of such request for a private letter ruling and, as allowed by law, shall execute either a privacy act waiver or a limited power of attorney, in a form acceptable to the IRS, that authorizes Interconnector to participate in all discussions with the IRS regarding such request for a private letter ruling. Operator shall allow Interconnector to attend all meetings with IRS officials about the request and shall permit Interconnector to prepare the initial drafts of any follow-up letters in connection with the request.

- 15.6. Subsequent Taxable Events: If, within ten (10) years from the date on which the relevant JPP Interconnection Facilities are placed in service (i) Interconnector breaches the covenants contained in Section 15.2, (ii) a "disqualification event" occurs within the meaning of IRS Notice 88-129, or (iii) this Agreement terminates and ANPP Switchyard Participants retain ownership of the JPP Interconnection Facilities, Interconnector shall pay a tax gross-up for the cost consequences of any current tax liability imposed on ANPP Switchyard Participants, calculated using the methodology described in Section 15.4 and in accordance with IRS Notice 90-60.

- 15.7. Contests: In the event any Governmental Authority determines that ANPP Switchyard Participants' receipt of payments or property constitutes income that is subject to taxation, Operator shall notify the Interconnector, in writing, within thirty (30) calendar days of receiving notification of such determination by a Governmental Authority. Upon the timely written request by Interconnector and at Interconnector's sole expense, Operator may appeal, protest, seek abatement of, or otherwise oppose such determination. Upon Interconnector's written request and sole expense, Operator may file a claim for refund with respect to any taxes paid under

this Article 15, whether or not it has received such a determination. ANPP Switchyard Participants reserve the right to make all decisions with regard to the prosecution of such appeal, protest, abatement or other contest, including the selection of counsel and compromise or settlement of the claim, but Operator shall keep Interconnector informed, shall consider in good faith suggestions from Interconnector about the conduct of the contest, and shall reasonably permit Interconnector or an Interconnector representative to attend contest proceedings.

Interconnector shall pay to ANPP Switchyard Participants on a periodic basis, as invoiced by Operator, ANPP Switchyard Participants' documented reasonable costs of prosecuting such appeal, protest, abatement or other contest. At any time during the contest, ANPP Switchyard Participants may agree to a settlement either with Interconnector's consent or after obtaining written advice from nationally-recognized tax counsel, selected by ANPP Switchyard Participants, but reasonably acceptable to Interconnector, that the proposed settlement represents a reasonable settlement given the hazards of litigation. Interconnector's obligation shall be based on the amount of the settlement agreed to by Interconnector, or if a higher amount, so much of the settlement that is supported by the written advice from nationally-recognized tax counsel selected under the terms of the preceding sentence. The settlement amount shall be calculated on a fully grossed-up basis to cover any related cost consequences of the current tax liability. Any settlement without Interconnector's consent or such written advice will relieve Interconnector from any obligation to indemnify ANPP Switchyard Participants for the tax at issue in the contest.

- 15.8. **Refund:** In the event that (a) a private letter ruling is issued to ANPP Switchyard Participants which holds that any amount paid or the value of any property transferred by Interconnector to ANPP Switchyard Participants under the terms of this Agreement is not subject to federal income taxation, (b) any legislative change or administrative announcement, notice, ruling or other determination makes it reasonably clear to ANPP Switchyard Participants in good faith that any amount paid or the value of any property transferred by Interconnector to ANPP Switchyard Participants under the terms of this Agreement is not taxable to ANPP Switchyard Participants, (c) any abatement, appeal, protest, or other contest results in a determination that any payments or transfers made by Interconnector to ANPP Switchyard Participants are not subject to federal income tax, or (d) if ANPP Switchyard Participants receive a refund from any taxing authority for any overpayment of tax attributable to any payment or property transfer made by Interconnector to ANPP Switchyard Participants to this Agreement, Operator shall promptly refund to Interconnector the following:

(i) any payment made by Interconnector under this Article 15 for taxes that is attributable to the amount determined to be non-taxable, together with interest thereon,

(ii) interest on any amounts paid by Interconnector to ANPP Switchyard Participants for such taxes which ANPP Switchyard Participants did not submit to the taxing authority, calculated in accordance with the methodology set forth in FERC's regulations at 18 CFR § 35.19a (a)(2)(iii) from the date payment was made by Interconnector to the date Operator refunds such payment to Interconnector, and

(iii) with respect to any such taxes paid by ANPP Switchyard Participants, any refund or credit ANPP Switchyard Participants receive or to which they may be entitled from any Governmental Authority, interest (or that portion thereof, attributable to the payment described in clause (i), above) owed to ANPP Switchyard Participants for such overpayment of taxes (including any reduction in interest otherwise payable by ANPP Switchyard Participants to any Governmental Authority resulting from an offset or credit); provided, however, that ANPP Switchyard Participants will remit such amount promptly to Interconnector only after and to the extent that ANPP Switchyard Participants have received a tax refund, credit or offset from any Governmental Authority for any applicable overpayment of income tax related to JPP Interconnection Facilities.

The intent of this provision is to leave the Parties, to the extent practicable, in the event that no taxes are due with respect to any payment for JPP Interconnection Facilities hereunder, in the same position they would have been in had no such tax payments been made.

- 15.9. Contesting, Appealing, or Seeking Abatement of Taxes Other than Income Taxes: Upon the timely request by Interconnector, and at Interconnector's sole expense, ANPP Switchyard Participants may appeal, protest, seek abatement of, or otherwise contest any tax (other than federal or state income tax) asserted or assessed against ANPP Switchyard Participants for which the Interconnector may be required to reimburse the ANPP Switchyard Participants under this Agreement. Interconnector shall pay to ANPP Switchyard Participants on a periodic basis, as invoiced by Operator, ANPP Switchyard Participants' documented reasonable costs of prosecuting such appeal, protest, abatement, or other contest. Interconnector and ANPP Switchyard Participants shall cooperate in good faith with respect to such contest. Unless the payment of such taxes is a prerequisite to an appeal or abatement or cannot be deferred, no amount shall be payable by Interconnector to ANPP Switchyard Participants for such taxes until they are assessed by a final, non-appealable order by any court or agency of competent jurisdiction. In the event that a tax payment is withheld and ultimately due and payable after appeal, Interconnector will be responsible for all taxes, interest and penalties, other than penalties attributable to any delay caused by ANPP Switchyard Participants.

16. INSURANCE:

- 16.1. The Operator, on behalf of the ANPP Switchyard Participants shall procure and maintain, or cause to be procured or maintained, with respect to the HAA and the JPP Interconnection Facilities, the insurance coverages as set forth in the ANPP Switchyard Participation Agreement and depicted in Exhibit 7, INSURANCE, attached hereto and incorporated by this reference; provided that coverages applicable to the HAA and the JPP Interconnection Facilities may be amended, in the discretion of the Operator, if like amendments are made for insurance coverages for the PV Switchyard and Operator shall provide reasonable advance notice to the Shared Facilities Manager to the extent practicable and if advance notice is not practicable, promptly after such amendments are made. To the extent insurance procured by the Operator for the HAA and the JPP Interconnection Facilities and insurance maintained by the Interconnector both apply to a loss, insurance procured for the HAA and the JPP Interconnection Facilities shall be primary and not excess or contributory to any insurance maintained by Interconnector. If requested by the Shared Facilities Manager, the Operator shall furnish the Shared Facilities Manager certificates, within thirty (30) calendar days of the Effective Date, of such insurance evidencing the coverage required to be purchased and maintained by the Operator. Such certificates shall provide that thirty (30) calendar days' advance written notice shall be given to the Shared Facilities Manager prior to termination or cancellation of, or material change in, the coverage, or if thirty (30) calendar days is not available, the longest notice period, if any, as is reasonably available and ten (10) calendar days for non-payment of premium.
- 16.2. The Operator will hold and apply proceeds received by it under insurance policies covering loss or damage to the HAA and the JPP Interconnection Facilities for the purpose of restoring the functionality of the HAA and the JPP Interconnection Facilities. In the event that such proceeds are, in the judgment of the Operator, insufficient to restore the HAA and the JPP Interconnection Facilities to its design specifications, the Parties shall proceed in accordance with Section 8.4 herein.
- 16.3. Interconnector shall, at its expense, be solely responsible to provide and maintain in effect for the term of this Agreement, insurance against the risks set forth in this Section 16.3.
- 16.3.1. Workers' compensation insurance with minimum statutory limits to cover obligations imposed by federal and state statutes having jurisdiction over the Interconnector's employees and Employer's Liability Insurance with a minimum limit of one million dollars (\$1,000,000) per accident.
- 16.3.2. Commercial general liability insurance, including contractual liability, broad form property damage, premises operations, and personal injury coverage in the amount of five million dollars

(\$5,000,000) per occurrence for bodily injury and property damage. Such insurance shall cover the Operator and the ANPP Switchyard Participants as additional insureds.

16.3.3. "All Risk" Property/Boiler and Machinery insurance including earthquake, and flood with reasonable and customary sub-limits covering the Generating Facility. Such insurance shall provide coverage on a replacement cost basis for the Generating Facility.

16.3.4. All insurance policies shall provide for thirty (30) calendar days' advance written notice of cancellation or material adverse change, ten (10) calendar days for non-payment of premium. Prior to the initial date of synchronization of the Generating Facility, and annually thereafter upon request by Operator, Interconnector shall provide evidence of insurance to the Operator.

16.3.5. Interconnector may, in lieu of purchasing insurance from any third party, self-insure against all or any portion of any of the risks set forth in this Section 16.3. Without limiting the foregoing, any deductible and any limitation on the total amount of insurance shall constitute self-insurance for purposes hereof. Interconnector shall provide to Operator a description of any self-insurance used in complying with any of the insurance requirements of this Article 16 at least thirty (30) calendar days prior to initiating or amending any program of self-insurance.

16.4. The requirements contained in this Article 16 as to the types and limits of insurance to be maintained by each Party are not intended to and shall not in any manner limit or qualify the liabilities and obligations assumed by the Parties under this Agreement.

17. INDEMNITY, LIABILITY LIMITS AND DAMAGE DISCLAIMERS:

17.1. Indemnity: Interconnector shall at all times indemnify, defend and save the Operator and ANPP Switchyard Participants harmless for, from and against any and all damages, losses, claims, including claims and actions relating to injury to or death of any person or damage to or loss of property, demands, suits, recoveries, costs and expenses, court costs, attorneys' fees, and all other obligations by or to third parties, arising out of or resulting from the Operator's performance of its obligations under this Agreement on behalf of Interconnector, except in cases of negligence or intentional wrongdoing by the Operator.

17.2. Limitation of Liability and Disclaimer of Certain Damages by Interconnector: In no event shall a) Interconnector's liability, if any, for each claim relating to the subject matter of this Agreement exceed ten million dollars (\$10,000,000) in Constant Dollars, and b) Interconnector be liable for any

special, indirect, incidental, consequential or punitive damages, including but not limited to loss of profit or revenue, loss of the use of equipment, cost of capital, cost of temporary equipment or services, whether based on breach of contract, negligence, gross negligence, willful misconduct, strict liability or other causes of action. All payments due for services under this Agreement shall be deemed to constitute direct (and not special, incidental, indirect or consequential) damages for purposes of this Section 17.2. The provisions, limitations and disclaimers of this Section 17.2 shall not apply to each of the following items: (i) claims for indemnity under Section 17.1, (ii) any amounts payable by Interconnector pursuant to Section 11.3 herein, and (iii) any claim for physical injury to or destruction of the real property or tangible personal property of an ANPP Switchyard Participant, which claim shall be limited to the amounts required to fully abate or repair damage to or to replace such property.

17.3. Limitation of Liability and Disclaimer of Certain Damages by Operator and ANPP Switchyard Participants: In no event shall a) the liability, if any, of Operator or any or all ANPP Switchyard Participants, separately or in the aggregate, for each claim relating to the subject matter of this Agreement exceed, in total, ten million dollars (\$10,000,000) in Constant Dollars, and b) any ANPP Switchyard Participant or Operator be liable for any special, indirect, incidental, consequential or punitive damages, including but not limited to loss of profit or revenue, loss of use of equipment, cost of capital, cost of temporary equipment or services, whether based on breach of contract, negligence, gross negligence, willful misconduct, strict liability or other causes of action. In the event there are multiple claims which arise out of the same occurrence, even if such multiple claims are made under the provisions of other interconnection agreements associated with the HAA, all such multiple claims shall be deemed to be a single claim arising out of a single occurrence. The aggregate limit of liability with respect to such occurrence shall be ten million dollars (\$10,000,000) and shall apply regardless of the number of claims arising out of the same occurrence. The provisions, limitations and disclaimers of this Section 17.3 shall not apply to any claim for physical injury to or destruction of the real property or tangible personal property of Interconnector, which claim shall be limited to the amounts required to fully abate or repair damage to or to replace such property.

17.4. No Relief of Insurer: The provisions of this Article 17 shall not be construed so as to relieve any insurer of its obligation to pay any insurance proceeds in accordance with the terms and conditions of valid and collectible insurance policies furnished hereunder.

18. UNCONTROLLABLE FORCES:

No Party shall be considered to be in default in the performance of its obligations hereunder (other than the obligations of said Party to make payment of bills rendered

hereunder) when a delay in or failure of performance shall be due to an Uncontrollable Force. The term "Uncontrollable Force" shall mean any cause beyond the reasonable control of the Party affected, including but not restricted to failure of facilities, flood, earthquake, storm, fire, lightning, epidemic, war, riot, civil disturbance or disobedience, labor dispute, labor, fuel, transportation or material shortage, sabotage, regulation or restriction imposed by governmental or lawfully established authority, restraint by court order or public authority, which by exercise of due diligence such Party could not reasonably have been expected to avoid and which by exercise of due diligence it shall be unable to overcome. Nothing contained herein shall be construed to require a Party to settle any strike or labor dispute in which it may be involved. Any Party that fails to fulfill any of its obligations hereunder by reason of an Uncontrollable Force shall give prompt written notice of such fact to the other Parties and an estimate, if possible, of when the Party claiming the Uncontrollable Force believes in good faith that the Uncontrollable Force will end and performance will resume. The Party claiming the Uncontrollable Force shall exercise due diligence to resume the performance of such obligation(s) with all reasonable dispatch.

19. RELATIONSHIP OF THE PARTIES:

Except as expressly provided otherwise herein, the covenants, obligations and liabilities of the Parties are intended to be several and not joint or collective. Nothing contained herein shall ever be construed to create an association, joint venture, trust, or partnership, or to impose an association, joint venture, trust or partnership covenant, obligation, or liability on or with regard to any one or more of the Parties. Except as expressly provided otherwise herein, each Party shall be individually responsible for its own covenants, obligations, and liabilities as herein provided. No Party or group of Parties shall be under the control of nor shall be deemed to control any other Party or the Parties as a group. No Party shall be the agent of or have a right or power to bind any other Party without its express written consent, except as expressly provided in this Agreement. Interconnector hereby expressly acknowledges and agrees that Operator is not an agent or representative of Interconnector for any purpose.

20. SUCCESSORS AND ASSIGNS:

20.1. The Interconnector shall not transfer or assign or otherwise dispose of (a "Transfer") all or any part of its rights or interests under this Agreement without the prior written approval of the ANPP Switchyard Participants, which approval shall not be unreasonably withheld, conditioned, or delayed. Notwithstanding the foregoing, the Interconnector may make Transfers as collateral security to one or more affiliated or unaffiliated third-party lenders and/or to any trust which has entered into an agency agreement in conjunction with the financing of the Generating Facility (a "Financing Transfer") without the ANPP Switchyard Participants' prior approval but shall give prompt notice of any such Financing Transfer to the ANPP Switchyard Participants, and any entity acquiring the transferred interests pursuant to a foreclosure (or any Transfer in lieu of foreclosure thereof) shall be subject to approval by the ANPP Switchyard Participants, which approval

shall not be unreasonably withheld, conditioned or delayed. Any purported Transfer which does not (i) except for a Financing Transfer, include all surviving provisions of the Funding Agreement, and (ii) comply with the requirements of this Section 20.1, shall be ineffective as between the ANPP Switchyard Participants and the Interconnector and shall not confer upon the transferee any right, title or interest under this Agreement or in or to the HAA and/or JPP Interconnection Facilities. A sale of all or any part of the stock, partnership, membership or other ownership interest in the Interconnector shall not be deemed a Transfer for purposes of this Article 20.

- 20.2. Subject to Section 20.1 herein, this Agreement shall be binding upon and inure to the benefit of the Parties and their respective successors and assigns, or purchasers of any interests of the Parties in the Common Bus.
- 20.3. The ANPP Switchyard Participants shall promptly notify the Shared Facilities Manager of any change in the identity of the Operator. If the ANPP Switchyard Participants request approval of any such change in order to satisfy Applicable Requirements, they shall concurrently notify the Shared Facilities Manager of such request. No Person serving as Operator hereunder shall be liable for any acts or omissions of any predecessor or successor Operator. To the extent that the Operator is acting as an agent of the ANPP Switchyard Participants, the liability of the Operator and of the ANPP Switchyard Participants for acts or omissions of the Operator shall be determined in accordance with the legal principles applicable to agency in the State of Arizona and other Law. Subject to the obligation to comply with Applicable Requirements and the receipt of necessary authorizations hereunder, if any, nothing in this Agreement is intended to or shall be deemed to prohibit the ANPP Switchyard Participants from appointing an Operator which is an independent contractor, rather than an agent. In such event, the Operator shall be deemed a Party to this Agreement, and the liability of the Operator and the ANPP Switchyard Participants shall be governed by the legal principles applicable to independent contractors in the State of Arizona and other Law. Nothing herein is intended to waive the right of any Party to contest whether the Operator is an agent or an independent contractor or the effect of the Arizona legal principles applicable to such relationships under the circumstances. Nothing herein is intended to modify the obligations of any Party to comply with Applicable Requirements or to waive, expressly or impliedly, the right of any Party to exercise all legal, equitable, regulatory or other remedies, including without limitation any rights or obligations to apply, protest or comment to FERC or participate in any FERC proceeding.

21. AUDITS:

- 21.1. Right: Subject to Section 21.2 hereof, the Interconnector shall have the right: (i) to audit any costs, payments, settlements, or other supporting

information pertaining to costs payable by Interconnector pursuant to this Agreement; and (ii) to designate its own representatives to perform such audit. At least sixty (60) calendar days prior to requesting an audit, the Interconnector shall provide notice to the Operator, other Parties and all other Hassayampa Interconnectors of its intent to audit and the proposed scope of such audit. Any other Hassayampa Interconnector shall have the right to join in and expand the scope of such audit. The Parties and Operator agree to fully cooperate with any such audit(s). Notwithstanding the foregoing, Interconnector shall not have the right to audit costs associated with the shared JPP Interconnection Facilities if any other SS Entity has already conducted an audit of such costs within the same calendar year.

- 21.2. Conditions: Any audit undertaken by the Interconnector or by the representatives thereof shall: (i) be conducted only during Operator's normal business hours; (ii) be performed in conformance with generally accepted auditing standards; and (iii) be limited to the three (3) year period following the end of the calendar year in which the costs being audited were invoiced. In no event, however, shall the Interconnector be entitled to conduct an audit pursuant to the provisions of this Agreement, if the Interconnector or any other Hassayampa Interconnector has conducted an audit in the same calendar year.
- 21.3. Costs: All audit costs and expenses of the Interconnector shall be its sole responsibility.
- 21.4. Record Retention Period: Operator shall retain all necessary records and documents for the three (3) year audit period specified in Section 21.2 hereof, or until any audit in progress is completed or until any dispute arising from such audit is resolved, whichever condition requires the longer retention.
- 21.5. Notice: Upon completion of any audit conducted hereunder, the Interconnector shall promptly make such audit results available to the Operator, each Party and all other Hassayampa Interconnectors, and shall provide notice to Operator, to each Party and all other Hassayampa Interconnectors of any exception taken as a result of an audit. If Operator and the Interconnector determine that an exception resulting from an audit reflects an error in the billing, Operator, in the next succeeding monthly invoice(s), shall credit or bill the Interconnector for the amount of such exception, without interest.

22. DEFAULTS:

- 22.1. General: No default shall exist under this Agreement where such failure to discharge an obligation (other than the payment of money) is the result of

Uncontrollable Forces as defined in this Agreement or the result of an act of omission of any other Party. Upon a breach, the non-breaching Party shall give written notice of such breach to the breaching Party. Without limiting Section 22.2, the breaching Party shall have thirty (30) calendar days from receipt of the default notice within which to cure such breach; provided however, if such breach is not capable of cure within thirty (30) calendar days, the breaching Party shall commence such cure within thirty (30) calendar days after notice and continuously and diligently complete such cure within ninety (90) calendar days from receipt of the default notice; and, if cured within such time, the breach specified in such notice shall cease to exist.

- 22.2. Disconnection: The SS Entities share a single Connection. Interconnector acknowledges and agrees that a default by another SS Entity of any obligation under its interconnection agreement with the ANPP Switchyard Participants that would permit the disconnection of such SS Entity's generating facility may result in the disconnection of the JPP Interconnection Facilities until such default has been fully and satisfactorily cured in accordance with the applicable SS Entity's interconnection agreement. The Interconnector acknowledges that disconnection of the JPP Interconnection Facilities, as provided in the previous sentence, will also result in an interruption of service for the Generating Facility, until the defaulting SS Entity has fully and satisfactorily cured the default in accordance with its interconnection agreement, and Interconnector acknowledges that such disconnection of the JPP Interconnection Facilities shall not constitute a default by ANPP Switchyard Participants under this Agreement or subject ANPP Switchyard Participants to any liability or damages hereunder and that Section 17.1 herein shall fully apply to any claims that may be asserted by third parties in connection with such disconnection. Operator will provide notice to the Shared Facilities Manager promptly following a default by any SS Entity under its interconnection agreement with the ANPP Switchyard Participants. Operator will allow the Generating Facility to return to service promptly after the defaulting SS Entity has cured its default under its interconnection agreement or such defaulting SS Entity's generation project has been disconnected from the shared Interconnector's Interconnection Facilities.
- 22.3. Right to Terminate: If a breach is not cured as provided in this Article 22, or if a breach is not capable of being cured within the period provided for herein, the non-breaching Party shall have the right to declare a default and terminate this Agreement by written notice at any time until cure occurs, and be relieved of any further obligation hereunder and, whether or not that Party terminates this Agreement, to recover from the breaching Party all amounts due hereunder, plus all other damages and remedies to which it is entitled at law or in equity.

22.4. Survivability: The provisions of this Article 22 will survive termination of this Agreement.

23. DISPUTE RESOLUTION:

Disputes under this Agreement between the Interconnector and the Operator or any of the ANPP Switchyard Participants (the "Disputants") will be resolved in accordance with the provisions of this Article 23.

23.1. Internal Dispute Resolution: Any dispute subject to this Article 23 shall, at the request of any Disputant, be referred to a senior representative of each of the Disputants for resolution on an informal basis as promptly as practicable. In the event the senior representatives are unable to resolve the dispute within thirty (30) calendar days of such referral or such other period as the Disputants may mutually agree, such dispute may, at the mutual agreement of the Disputants, be considered at the next E&O Committee meeting. If the Disputants do not mutually agree to have the dispute considered at the next E&O Committee meeting or do not resolve the dispute as a result of discussions with the E&O Committee, the matter may be submitted to arbitration or mediation on such terms and conditions as the Disputants may agree.

23.2. Rights Under the Federal Power Act: Nothing in this Article 23 shall restrict the rights of any Party or Operator to make a filing with the FERC under relevant provisions of the Federal Power Act, although the provisions set forth in Section 23.1 shall be exhausted prior to the exercising of rights pursuant to this Section 23.2.

23.3. Exercise of Remedies: Nothing in this Article 23 shall be construed to delay the exercise of remedies pursuant to Article 22 pending the resolution of any dispute.

24. NONDEDICATION OF FACILITIES:

The Parties do not intend to dedicate and nothing in this Agreement shall be construed as constituting a dedication by any Party of its properties or facilities, or any part thereof, to any other Party or to the customers of any Party.

25. REGULATORY APPROVALS:

25.1. Approvals: Each Party agrees to prepare and submit on a timely basis any required applications or other filings and to cooperate to obtain any state or federal regulatory approvals necessary for the full participation of any Party in the rights and obligations of this Agreement prior to the Interconnection Facilities In-Service Date. A Party shall concurrently notify the other Parties upon making any such submission. Each Party hereto covenants that it shall support the terms and conditions of this Agreement in any hearings before FERC or any other competent regulatory body to whose jurisdiction this Agreement may be subject.

26. GOVERNING LAW AND VENUE:

This Agreement shall be interpreted in accordance with the substantive and procedural laws of the State of Arizona, notwithstanding any Arizona conflict of laws provision to the contrary. Any court action arising under this Agreement shall be initiated and prosecuted in a state or federal court in Maricopa County, Arizona.

27. NOTICES:

27.1. Interconnector designates the Shared Facilities Manager as agent for receipt of notice as described in Sections 7.4, 8.1.6, 8.3, 12.1, 12.2, 12.3.1, 12.5, 16.1, 20.3, and 22.2 under this Agreement.

27.2. Recipients: Any legal notice or communication required by this Agreement shall be in writing, subject to the provisions in Section 12.3.2 herein regarding delivery of invoices, and shall be served, given, made, or delivered in person or sent by registered or certified mail, postage prepaid, to the persons specified in Appendix F ADDRESSES FOR DELIVERY OF NOTICES AND BILLINGS, as may be changed from time to time.

27.3. Routine Communication: Communications of a routine nature shall be provided to the Interconnector's Authorized Representative designated in Appendix F for receipt of routine communications and given in a manner consistent with the arrangements as established by the E&O Committee.

27.4. Change of Designation: Any Party may, at any time, by written notice to all other Parties, designate different or additional persons or different addresses for the giving of notices hereunder.

28. ANPP SWITCHYARD PARTICIPANTS' OTHER AGREEMENT:

This Agreement sets forth the terms and conditions under which the ANPP Switchyard Participants are providing interconnection service to the Interconnector, and this Agreement does not amend or otherwise affect the terms

and conditions governing the ANPP Switchyard Participants under their ANPP Switchyard Participation Agreement. In the event any conflict affecting the ANPP Switchyard Participants in their relationship with each other arises out of an inconsistency between the terms and conditions of this Agreement and the terms and conditions of the ANPP Switchyard Participation Agreement, the terms and conditions of the ANPP Switchyard Participation Agreement shall govern.

29. ENTIRE AGREEMENT:

This Agreement embodies the entire agreement between the Interconnector and the ANPP Switchyard Participants concerning the subject matter hereof and supersedes all prior proposals, representations, negotiations, or letters whether written or oral with respect to the matters herein agreed to. In the event any conflict affecting the Interconnector and the ANPP Switchyard Participants arises between the terms and conditions of this Agreement and the terms and conditions of the Funding Agreement, the terms and conditions of this Agreement shall govern. The Parties hereto shall not be bound by or be liable for any statement, representation, promise, inducement, or understanding of any kind relating to the subject matter hereof not set forth in this Agreement. This Agreement incorporates by reference all documents attached hereto and listed below or incorporated herein by reference. Included as appendices and exhibits to this Agreement and attached hereto are:

- Appendix A - Interconnection Facilities
- Appendix B - Milestones
- Appendix C - Interconnection Details
- Appendix D - Security Arrangement Details
- Appendix E - Commercial Operation Date
- Appendix F - Addresses for Delivery of Notices and Billings
- Exhibit 1 - Common Facilities
- Exhibit 2 - Common Facilities Use Fee
- Exhibit 3 - HAA Cost Responsibility Ratio (HAA CRR)
- Exhibit 4 - PV Switchyard Cost Responsibility Ratio (PV CRR)
- Exhibit 5 - Operating Work
- Exhibit 6 - Easement
- Exhibit 7 - Insurance

- Exhibit 8 - Mitigation Facility Fee
- Exhibit 9- Interconnection Costs

30. SECTION HEADINGS AND DEFINITIONS:

Section headings in this Agreement are for convenience only and are not to be construed to define, limit, expand, interpret, or amplify the provisions of this Agreement.

31. GENERAL PROVISIONS:

- 31.1. Severability: In the event that any term, covenant or condition of this Agreement, or the application of any such term, covenant or condition, shall be held invalid as to any person or circumstance by any court, agency, or other entity having jurisdiction in the premises, the Parties agree that the same shall not affect the validity of this Agreement as a whole, or any part of the Agreement other than the term, covenant, or condition held invalid, and the Parties agree to substitute for the invalid term, covenant, or condition a valid term, covenant, or condition which most closely approximates the economic effect and intent of the invalid term, covenant, or condition.
- 31.2. Third Party Rights: Except as otherwise specifically provided in this Agreement, the Parties do not intend to create rights in or to grant remedies to any third party as a beneficiary of this Agreement or of any duty, covenant, obligation or undertaking established herein.
- 31.3. Waiver: No waiver shall be effective unless in a writing signed by the waiving Party. Any waiver at any time by any Party of its rights with respect to a default or any other matter arising in connection with this Agreement shall not be construed or deemed a waiver with respect to any other right or remedy or any subsequent default or matter whether of a similar or different nature. Without limiting the foregoing, payment or delay in exercising any right or remedy shall not constitute a waiver of any kind.
- 31.4. Survival: The termination of this Agreement shall not relieve any Party of its obligations, duties, rights, or requirements under this Agreement incurred prior to termination of this Agreement or which, pursuant to the terms hereof, must be fulfilled or met after the date of termination of this Agreement.
- 31.5. Amendments and Revisions to Appendices or Exhibits: Except as provided in the next sentence, this Agreement shall only be modified by an amendment signed by all Parties. Exhibits 2, 3, and 4 to this Agreement may be revised by the Operator; subject, however, to the approval of the E&O Committee. The other appendices or exhibits to this Agreement may

be revised by mutual agreement of Interconnector and the Operator; subject, however, to the approval of the E&O Committee.

- 31.6. Compliance with Law: Facilities installed under this Agreement by Operator shall be constructed, operated, maintained, replaced, upgraded, modified and removed in compliance with any Law, including without limitation, any Law protecting the environment, health, and/or safety.
- 31.7. Interference or Impairment: Except as expressly provided herein, nothing in this Agreement shall interfere with or impair the rights or entitlements of any Party under Applicable Requirements.

32. EXECUTION:

- 32.1. Execution by Counterparts: This Agreement may be executed in multiple counterparts, each of which will be deemed an original and all of which, when taken together, constitute one and the same instrument. Copies of signatures transmitted electronically (including by .pdf file exchanged via email or other electronic transmission) will be deemed effective as originals.
- 32.2. Execution and Delivery: Upon receipt of all signature pages from all the other Parties, Operator shall: (i) promptly notify the Parties of the date of execution and delivery for the purposes of Section 5.1 hereof, which shall be the date on which the last Party executes such signature pages, and (ii) send to each Party, by email, a complete set of signature pages.

33. SIGNATURE CLAUSE:

The signatories hereto represent that they have been appropriately authorized to enter into this Agreement on behalf of the Party for whom they sign.

INTERCONNECTOR:

SUN STREAMS 2, LLC

By: _____

Title: _____

Date: _____

ANPP SWITCHYARD PARTICIPANTS:

ARIZONA PUBLIC SERVICE COMPANY

By: _____

Title: _____

Date: _____

EL PASO ELECTRIC COMPANY

By: _____

Title: _____

Date: _____

CITY OF LOS ANGELES BY AND THROUGH THE DEPARTMENT OF WATER AND POWER

BY: BOARD OF WATER AND POWER COMMISSIONERS OF THE CITY OF LOS ANGELES

Date: _____

By: _____

MARTIN L. ADAMS

Title: General Manager and Chief Engineer

And

By: _____

SUSAN A. RODRIGUEZ, Secretary

Date: _____

PUBLIC SERVICE COMPANY OF NEW MEXICO

By: _____

Title: _____

Date: _____

SALT RIVER PROJECT AGRICULTURAL IMPROVEMENT AND POWER DISTRICT

By: _____

APPROVED AS TO FORM AND LEGALITY
MICHAEL N. FEUER, CITY ATTORNEY

NOV 01 2019

BY: *Synda Driscoll*
SYNDA DRISCOLL
DEPUTY CITY ATTORNEY

ARIZONA PUBLIC SERVICE COMPANY

By: _____

Title: _____

Date: _____

EL PASO ELECTRIC COMPANY

By: *Scott D. ...*

Title: SR VP - OPERATIONS

Date: 10/3/19

APPROVED AS TO FORM
OFFICE OF THE GENERAL COUNSEL *[Signature]*

DEPARTMENT OF WATER AND POWER OF THE CITY OF LOS ANGELES

By: _____

Title: _____

Date: _____

PUBLIC SERVICE COMPANY OF NEW MEXICO

By: _____

Title: _____

Date: _____

SALT RIVER PROJECT AGRICULTURAL IMPROVEMENT AND POWER DISTRICT

By: _____

ARIZONA PUBLIC SERVICE COMPANY

By: _____

Title: _____

Date: _____

EL PASO ELECTRIC COMPANY

By: _____

Title: _____

Date: _____

DEPARTMENT OF WATER AND POWER OF THE CITY
OF LOS ANGELES

By: _____

Title: _____

Date: _____

PUBLIC SERVICE COMPANY OF NEW MEXICO

By: *Paul H. Hilly*

Title: *VP, New Mexico Operations*

Date: *10/14/2019*

SALT RIVER PROJECT AGRICULTURAL IMPROVEMENT
AND POWER DISTRICT

By: _____

ARIZONA PUBLIC SERVICE COMPANY

By: _____

Title: _____

Date: _____

EL PASO ELECTRIC COMPANY

By: _____

Title: _____

Date: _____

DEPARTMENT OF WATER AND POWER OF THE CITY
OF LOS ANGELES

By: _____

Title: _____

Date: _____

PUBLIC SERVICE COMPANY OF NEW MEXICO

By: _____

Title: _____

Date: _____

SALT RIVER PROJECT AGRICULTURAL IMPROVEMENT
AND POWER DISTRICT

By: *Nate Tate*

Title: Director, SRP Substation Design Construction and Maintenance

Date: October 9, 2019

SOUTHERN CALIFORNIA PUBLIC
POWER AUTHORITY

By: _____

Title: _____

Date: _____

SOUTHERN CALIFORNIA EDISON COMPANY

By: _____

Title: _____

Date: _____

Title: _____

Date: _____

**SOUTHERN CALIFORNIA PUBLIC
POWER AUTHORITY**

By: _____

Title: _____

Date: _____

SOUTHERN CALIFORNIA EDISON COMPANY

By: *Jill Ober*

Title: *Director GRID CONTRACTS ORIGINATOR & OPERATIONS*

Date: *October 30, 2019*

APPENDIX A

INTERCONNECTION FACILITIES

- A.1 Interconnector's Interconnection Facilities (See Appendix C, Figures 1 and 3):
 - A.1.1 All facilities from the Generating Facility up to, and including, the first tower outside the fence of HAA which must be a self-supporting "non-guyed" dead end structure.
- B.1 JPP Interconnection Facilities (See Appendix C, Figures 1 and 3):
 - B.1.1 One (1) dead end structure (located within the HAA fence).
 - B.1.2 Two (2) 500 kV circuit breakers, two (2) sets of three (3) current transformers housed within the breakers, one (1) set of three (3) metering quality coupling capacitor voltage transformers, and four (4) disconnect switches (one with ground blades).
 - B.1.3 Switch supports, CT supports, bus supports, CCVT supports, and tie-down structures.
 - B.1.4 Insulators, conductors and associated hardware.
 - B.1.5 Protective relaying systems, metering, and interface with control, monitoring and communication equipment.
 - B.1.6 Structure and equipment foundations, grounding and conduit.
- C.1 Electrical Diagram of interconnection facilities: See Appendix C.

APPENDIX B

MILESTONES

1. Commercial Operation Date – December 31, 2021
2. Requested In-Service Date – March 31, 2021

The California Independent System Operator Corporation ("CAISO") and SCE identified their transmission systems as potential affected systems with respect to the interconnection of the Generating Facility. Prior to the In-Service Date, Interconnector will provide documentation to the Operator that demonstrates to Operator's reasonable satisfaction that there are no system reliability impacts to the CAISO and SCE systems that require mitigation or that any system reliability impacts have been mitigated, and that such mitigation has been accepted by CAISO and SCE.

APPENDIX C

INTERCONNECTION DETAILS

Generating Facility: The Sun Streams 2 project is a 150 MWac (net) solar photovoltaic ("PV") generating facility, generally located in Arlington, Maricopa County, located on the corner of Narramore Road and 355th Avenue, approximately 1 mile southeast of the southeastern edge of HAA.

The 150 MW Generating Facility will be designed to meet FERC's order 827 for dynamic voltage control, and FERC order 842 for the frequency response. The project active power control consists of power curtailment, ramp rate control, frequency control, power limit control, and plant start and shutdown. The controller controls active power generation at the point of interconnection such that plant never exceeds the maximum MW based on PPA/Interconnection Request. The project will have capabilities to operate in automatic voltage regulation (AVR) or power-factor (PF) regulation mode.

The project will use First Solar PV modules mounted on support structures arranged in 48 blocks. Each block consists of multiple strings of PV panels connected to a power conversion station (PCS) comprising one (1) 3.249 MW / 3.420 MVA PE HEM FS3350M inverter and one (1) integrated 3.465 MVA 34.5 kV Delta: 630 V Wye transformer. Inverter MW output rating (3.249 MW / 3.42 MVA) already covers the losses within the integrated PCS transformer. PCSs will be connected in daisy chain configuration and then connected to a photovoltaics combining switchgear (PVCS). There is a final voltage change at the substation to convert the collection system 34.5 kV voltage to the interconnection voltage of 525 kV via one (1) substation transformer rated 96/128/160 MVA, 525 kV Y-G: 34.5 kV Y-G with a buried delta tertiary. The project will be connected through a 0.5 mile gen-tie to the substation shared by the SS Entities ("Chukar"). Chukar will be connected through a 0.5 mile gen-tie to the 500 kV Hassayampa bus.

Point of Interconnection (POI): The "Point of Interconnection" with the ANPP system is the 500 kV bus at the HAA.

Point of Change of Ownership (PCO): The Point of Change of Ownership occurs at two locations on the line connecting the Generating Facility to HAA; 1) where the line conductor emanating out of HAA to the Generating Facility attaches to the jumper on the first structure outside the HAA fence and 2) where the insulator and associated Connection hardware on the line conductor emanating out of HAA to the Generating Facility attach to the first structure outside the HAA fence as detailed in Figure 2 below. All equipment from HAA up to but not including the first tower outside the fence of HAA will be owned by the ANPP Switchyard Participants.

Figures: Figure 1 shows the PCO and POI and a high level view of the JPP Interconnection Facilities and Interconnector's Interconnection Facilities. Figure 2 is a detailed diagram showing the PCO. Figure 3 is a detailed diagram showing the interconnection facilities at the first tower outside the fence of HAA. Figure 4 is a one line diagram of HAA showing the interconnection of Sun Streams 2 Solar. Figure 5 is a modeling one-line diagram of Interconnector's Interconnection Facilities.

HASSAYAMPA

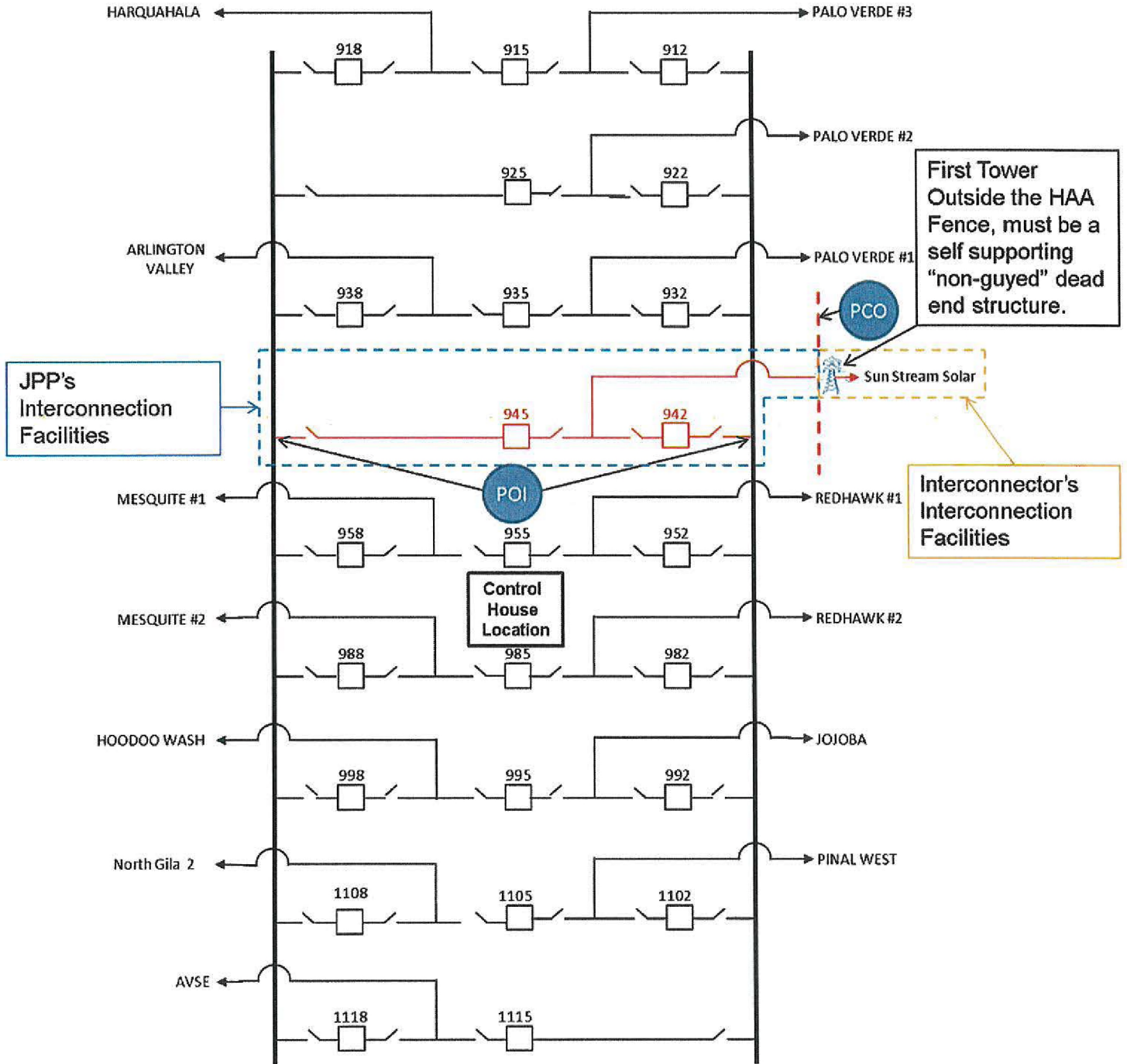

Figure 1: PCO and POI

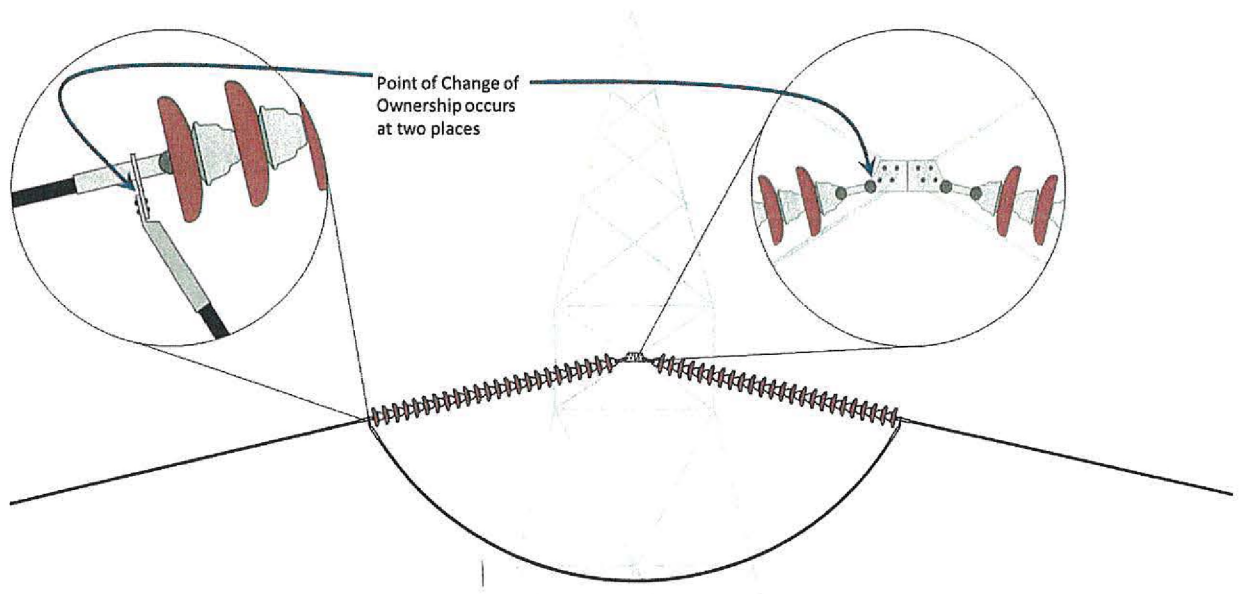

Figure 2: Detail of the Point of Change of Ownership

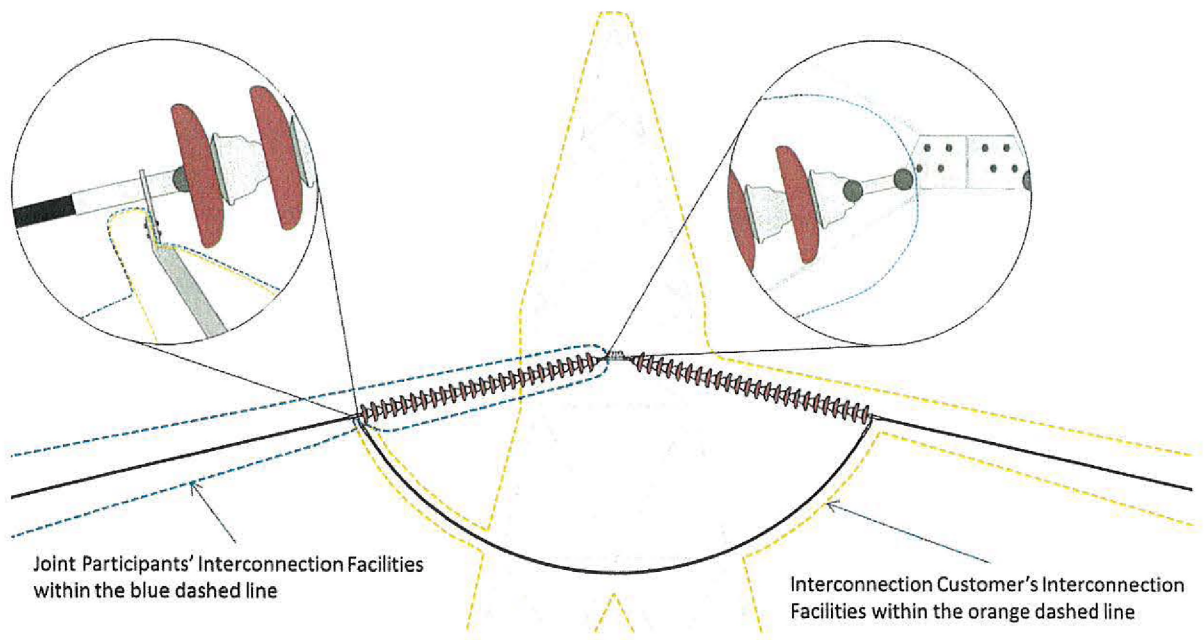

Figure 3: Detail of the interconnection facilities

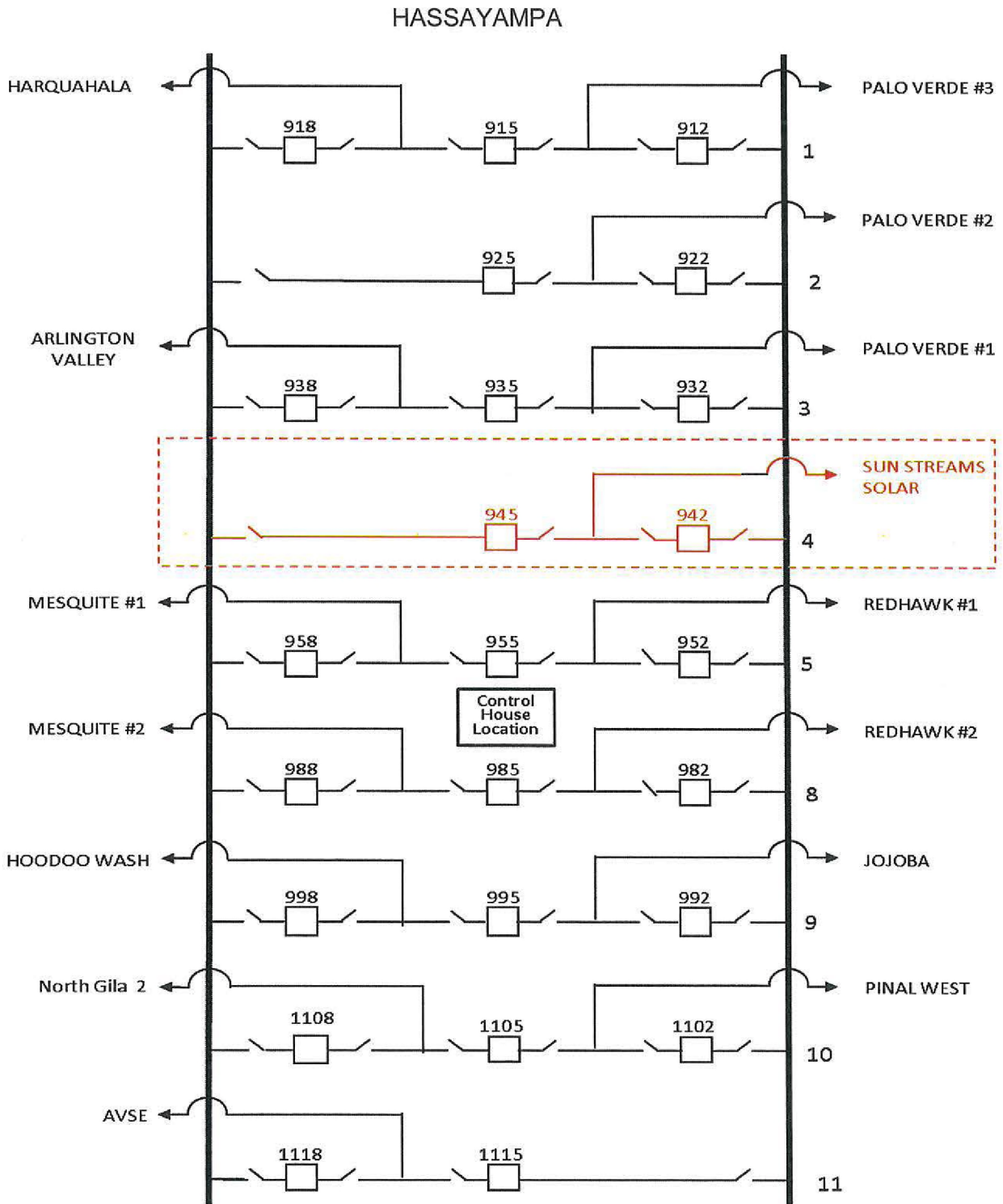

Figure 4: One line diagram of HAA showing the interconnection of Sun Streams 2 Solar

Sun Streams-2 Single Line Diagram

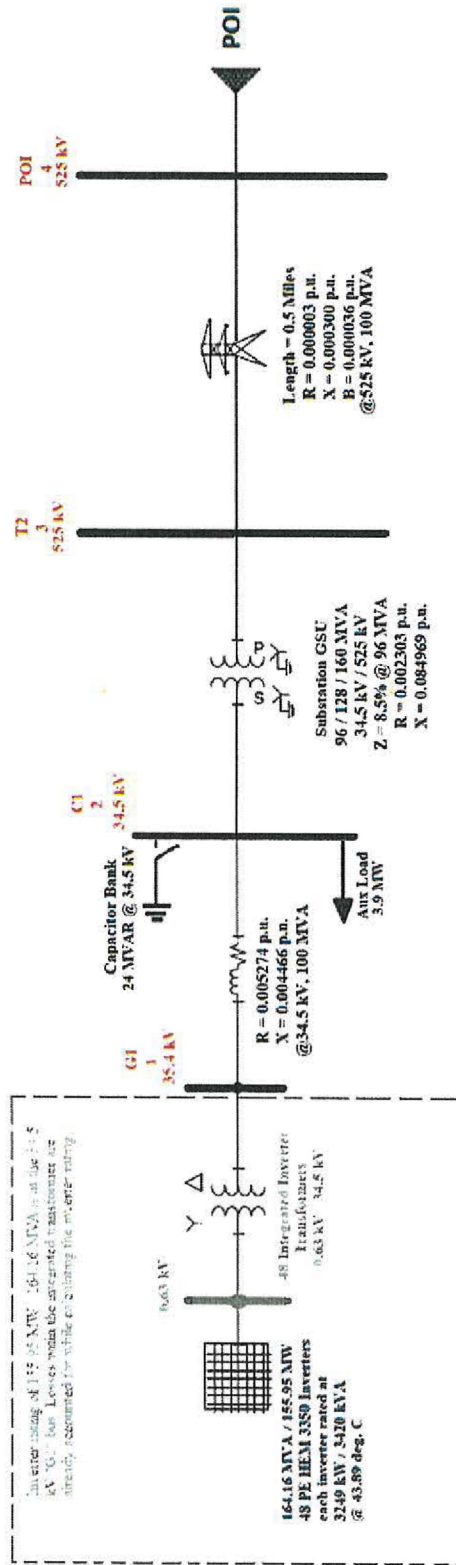

Figure 5 – Modeling One-Line of Interconnector’s Interconnection Facilities

APPENDIX D

SECURITY ARRANGEMENTS DETAILS

Infrastructure security of ANPP Switchyard-related equipment and operations and control hardware and software is essential to ensure day-to-day transmission system reliability and operational security. All ANPP Switchyard Participants, and Interconnectors interconnected to the ANPP Switchyard are expected to comply with the recommendations offered by the President's Critical Infrastructure Protection Board and, eventually, best practice recommendations from the electric reliability authority, as well as any subsequently-issued mandatory reliability standards or requirements. All public utilities will be expected to meet all applicable standards for system infrastructure and operational security, including physical, operational, and cyber-security practices.

APPENDIX E
COMMERCIAL OPERATION DATE

[Date]

[ANPP Switchyard Participant's Address]

Re: _____ Generating Facility

Dear _____:

On **[Date]** **[Interconnector]** has completed Trial Operation of Unit No. _____. This letter confirms that **[Interconnector]** commenced Commercial Operation of Unit No. _____ at the Generating Facility, effective as of **[Date plus one day]**.

Thank you.

[Signature]

[Interconnector Representative]

APPENDIX F

ADDRESSES FOR DELIVERY OF NOTICES AND BILLINGS

Notices:

ANPP Switchyard Participants:

Salt River Project
Attn: Manager, Transmission Participation & Interconnection Projects
Mail Station POB100
P.O. Box 52025
Phoenix, AZ 85072-2025
Phone: (602) 236-6688
Email: SRPInterconnections@srpnet.com

Interconnector:

Sun Streams 2, LLC
135 Main Street, 6th Floor San Francisco, CA 94105
Attention: Patricia Englin, Senior Manager, Transmission and Interconnection
Phone: 415-935-2536
Fax: 415-894-6207
E-Mail: patricia.englin@firstsolar.com
E-Mail: Interconnection.pdwest@firstsolar.com

With copies to:

Interconnector: Sun Streams 2, LLC
Attention: Melanie Falls, Senior Manager, Project Development
135 Main Street, 6th Floor
San Francisco, CA 94105
Phone: 415-935-2502
Fax: 415-894-6207
E-Mail: melanie.falls@firstsolar.com

Interconnector: Sun Streams 2, LLC
Attention: Beth Deane, Chief Counsel – Project Development
135 Main Street, 6th Floor
San Francisco, CA 94105
Phone: 415-935-2500
Fax: 415-894-6278
E-Mail: Beth.Deane@firstsolar.com
E-mail: generalcounsel@firstsolar.com

Shared Facilities Manager (Authorized Representative for technical and operational matters relating to the shared Interconnector's Interconnection Facilities):

Sun Streams Expansion, LLC
135 Main Street, 6th Floor San Francisco, CA 94105
Attention: Patricia Englin, Senior Manager, Transmission and Interconnection
Phone (24-Hour Telephone): 415-935-2536
Fax: 415-894-6207
E-Mail: patricia.englin@firstsolar.com
E-Mail: Interconnection.pdwest@firstsolar.com

With copies to:

Sun Streams Expansion, LLC
135 Main Street, 6th Floor San Francisco, CA 94105
Attention: Patricia Englin, Senior Manager, Transmission and Interconnection
Phone: 415-935-2536
Fax: 415-894-6207
E-Mail: patricia.englin@firstsolar.com
E-Mail: Interconnection.pdwest@firstsolar.com

Authorized Representative for Routine Communications and project-specific matters

Sun Streams 2
135 Main Street, 6th Floor San Francisco, CA 94105
Attention: Patricia Englin, Senior Manager, Transmission and Interconnection
Phone: 415-935-2536
Fax: 415-894-6207
E-Mail: patricia.englin@firstsolar.com
E-Mail: Interconnection.pdwest@firstsolar.com

Interconnector agrees to provide and maintain accurate contact information for the Shared Facilities Manager and Interconnector's Authorized Representatives. Interconnector shall provide notice to Operator of any change in the contact information for the Shared Facilities Manager or Interconnector's Authorized Representatives at least five (5) Business Days prior to such change taking effect.

Billings and Payments:

ANPP Switchyard Participants:

Salt River Project
Attn: Manager, Transmission Participation & Interconnection Projects
Mail Station POB100
P.O. Box 52025
Phoenix, AZ 85072-2025
Phone: (602) 236-6688
Email: SRPInterconnections@srpnet.com

Interconnector:

Sun Streams 2, LLC
Attention: First Solar Accounts Payable
28101 Cedar Park Blvd.
Perrysburg, OH 43551
Phone: N/A
Fax: N/A
E-Mail: fseinvoices@firstsolar.com

With a copy to:

Interconnector: Sun Streams 2, LLC
Attention: Melanie Falls, Senior Manager, Project Development
135 Main Street, 6th Floor
San Francisco, CA 94105
Phone: 415-935-2502
Fax: 415-894-6207
E-Mail: melanie.falls@firstsolar.com

EXHIBIT 1
COMMON FACILITIES

Common Facilities are broken down into two categories:

1. HAA Common Facilities.

The HAA Common Facilities are the mutual structures, devices, and systems inclusive to all interconnectors interconnecting to HAA. The HAA Common Facilities consist of, but are not limited to, the following:

- a. Land
- b. Site prep, roads, drainage ditch, and fence
- c. Ground grid
- d. Cable trench
- e. Main buses and their protection
- f. Control house
- g. Communication systems
- h. AC and DC auxiliary power systems
- i. Lighting systems
- j. Supervisory control systems and annunciator
- k. Digital fault recorder
- l. Security systems
- m. Common facilities terminations
- n. All facilities required for the Connection of the three string bus-ties to the PV Switchyard, the Jojoba line and the Hoodoo Wash line
- o. String bus-tie from PV Switchyard to HAA and all facilities required for the Connection of the string bus-tie at PV

2. PV Switchyard Common Facilities.

HAA is responsible for its pro-rata share of capital, operations and maintenance expenses of the PV Switchyard Common Facilities. The PV Switchyard Common Facilities are the mutual structures, devices, and systems inclusive to all interconnectors interconnecting to the PV Switchyard. The PV Switchyard Common Facilities consist of, but are not limited to, the following:

- a. Land
- b. Site prep, roads, drainage ditch, and fence
- c. Ground grid
- d. Cable trench
- e. Main buses and their protection
- f. Control house
- g. Communication systems
- h. AC and DC auxiliary power systems
- i. Lighting systems
- j. Supervisory control systems and annunciator
- k. Digital fault recorder
- l. Security systems
- m. Common facilities terminations

EXHIBIT 2

COMMON FACILITIES USE FEE

This Exhibit 2 provides the methodology for calculation of a one-time payment to be made pursuant to the Shared Facilities Responsible Project IA, on behalf of all of the SS Entities sharing the Connection, for use of Common Facilities at PV Switchyard and HAA.

Common Facilities Use Fee:

The one-time payment by Interconnector is calculated as follows:

$$P = ((OIC + X) \times HAA\ CRR) + (Y \times PV\ CRR)$$

Where:

- P = Payment by Interconnector for use of Common Facilities.
- OIC = Original installed costs¹ of HAA Common Facilities in the amount of \$42,180,556 and is for all costs from January 1999 thru August 2004 including the equipment and upgrades needed to connect the PV Switchyard to HAA.
- X = Cost of Capital Improvements of HAA Common Facilities from September 2004 to date².
- HAA CRR = Interconnector's HAA CRR calculated pursuant to Exhibit 3.
- Y = Cost of Capital Improvements of PV Switchyard Common Facilities from September 2004 to date³.
- PV CRR = Interconnector's PV CRR calculated pursuant to Exhibit 4.

$$\$5,308,434 = ((\$41,977,845 + \$10,724,272) \times 10\%) + (\$5,733,391 \times 1/150)$$

¹ The original installed costs shown here is less than the dollar amount that was reported to all interconnectors on page 2 of the "Project Completion & Final Cost Report (2004)" published by SRP. When the Mesquite II line terminated in Bay 8 West, Mesquite II paid \$202,711 for ½ of breaker 985 and disconnect switch 989 which were originally part of the HAA Common Facilities. As a result, the original installed costs of HAA Common Facilities was reduced by \$202,711 to the amount shown.

² The Cost of Capital Improvements of HAA Common Facilities will be determined to date of the execution of this Agreement.

³ The Cost of Capital Improvements of PV Switchyard Common Facilities will be determined to date of the execution of this Agreement.

EXHIBIT 3

HAA COST RESPONSIBILITY RATIO (HAA CRR)

This Exhibit 3 provides the computation of the HAA Cost Responsibility Ratio (HAA CRR):

$$\text{HAA CRR} = \frac{\text{HH}}{\text{HH} + \text{BB}}$$

Where:

HH = Number of Connections used by the Interconnector at HAA.

BB = Current total number of Connections at HAA excluding:

- The three (3) Connections for the string bus-ties to PV Switchyard
- The Connection for the Jojoba transmission line itself
- The Connection for the Hoodoo Wash transmission line itself
- The Connection used by the Interconnector at HAA

For Interconnector, the HAA CRR is calculated as follows:

HH = 1 (Interconnector has one Connection into bay 4 of HAA)

BB = 9 (Currently the Connections are: Harquahala (1), Mesquite (2), Red Hawk (2), Arlington Valley (1), Pinal West (1), AVSE (1), and HANG2 (1))

Therefore, the HAA CRR for the SS Entities sharing the Connection is:

$$\text{HAA CRR} = \frac{1}{1 + 9} = \frac{1}{10} = 10.00\%$$

EXHIBIT 4

PV SWITCHYARD COST RESPONSIBILITY RATIO (PV CRR)

This Exhibit 4 provides the computation of the PV Switchyard Cost Responsibility Ratio (PV CRR):

$$\text{PV CRR} = \frac{\text{XX}}{\text{ZZ}} \times \text{HAA CRR}$$

Where:

XX = Number of Connections in the PV Switchyard allocated to HAA.¹

ZZ = Current total number of Connections in the PV Switchyard:

HAA CRR = As calculated in Exhibit 3.

Therefore, PV CRR for Interconnector is:

XX = 1 (The Connection for the one string bus-tie at PV Switchyard that is allocated to HAA).

ZZ = 15 (Currently, fifteen terminations: PVNGS (7), Westwing (2), Rudd (1), HAA (1), Jojoba (1), Hoodoo Wash (1), Colorado River (1) and Delaney (1).

$$\text{HAA CRR} = \frac{1}{10} \text{ (From Exhibit 3)}$$

Therefore, the PV CRR for the SS Entities sharing the Connection is:

$$\text{PV CRR} = \frac{1}{15} \times \frac{1}{10} = \frac{1}{150}$$

¹ While there are three (3) string bus-ties between the PV Switchyard and HAA, only one of the three is allocated to HAA.

EXHIBIT 5

OPERATING WORK

This Exhibit 5 describes the Operating Work to be performed by Operator, as including, without limitation, all work performed by, or caused to be performed by, the Operator that is necessary for the operation and maintenance of the ANPP Switchyard, Hassayampa Interconnection Facilities, or JPP Interconnection Facilities, which work includes, but is not limited to, the work listed in the ANPP Switchyard Participation Agreement (engineering, agreement preparation, purchasing, repair, supervision, training, expediting, inspection, testing, protection, operation, retirement, maintenance, use, management, and making Capital Improvements). Operating Work shall include any work necessitated by an Operating Emergency and, except as set forth in Article 2 of this Exhibit 5, all work undertaken to make Capital Improvements.

1. Operating Costs shall consist of any expense, fee, loss, liability, charge, debit or other cost of any kind paid, incurred or suffered by Operator in the course of or as a result of performing any Operating Work. Such costs shall include, but not be limited to the following:

- 1.1 All of the Operator's internal costs of labor, services and studies performed as a part of Operating Work.
- 1.2 Payroll and other expenses of Operator's employees performing Operating Work, including without limitation properly allocated labor loading charges, such as department overhead, time-off allowance, payroll taxes, worker's compensation insurance, retirement and death benefits and other employee benefits; provided, however, that the Operator, acting in good faith, may allocate to the Operating Costs a reasonable percentage of the payroll and other expenses of any employee who, in accordance with the Operator's standard operating procedures, does not keep time sheets.
- 1.3 An allowance for the Operator's administrative and general expenses, to cover the costs of services rendered by it in the performance of Operating Work.
- 1.4 All costs for components of Operating Work, including without limitation overhead costs associated with Operating Work (including properly allocated department overheads), as set forth in the Electric Plant Instructions of the FERC Uniform System of Accounts.
- 1.5 All costs, including those of outside consultants and attorneys, incurred by the Operator or the ANPP Switchyard Participants with respect to the preparation of agreements relating to the HAA or Operating Work.
- 1.6 All costs of apparatus, including rental charges, and energy utilized for Operating Work.
- 1.7 All costs of insurance.

- 1.8 All federal, state or local taxes of any character imposed upon Operating Work.
- 1.9 All costs of relocating existing facilities including without limitation demolition and reconstruction, acquisition of lands and permits, and any upgrades or modifications required by Law or otherwise caused by Operating Work.
- 1.10 All costs of enforcing or attempting to enforce the provisions of insurance policies, payment and performance bonds, contracts executed by the Operator for Operating Work, and warranties obtained by the Operator and which are extended to the facilities to be provided hereunder.
- 1.11 Any other operating costs listed, described, or implicit in this Agreement.

2. Notwithstanding the foregoing, the following shall not constitute Operating Costs under this Agreement: any costs incurred in connection with (i) any work (including any work undertaken to make Capital Improvements or other modifications, additions, or upgrades) undertaken to facilitate the interconnection of any Non-Common Bus Interconnector; (ii) any work (including any work undertaken to make Capital Improvements, or other modifications, additions, or upgrades) undertaken to facilitate the provision of a transmission service request; (iii) any work associated with the installation of any Capital Improvements, modifications, additions, or upgrades to the Common Bus or any other transmission facilities in order to facilitate the Connection of any Hassayampa Interconnector that (a) is not a party to the Funding Agreement, or (b) is a party to the Funding Agreement, but requests an additional Connection to the HAA not provided for in the Funding Agreement; and (iv) any engineering, contract preparation, legal or regulatory work, purchasing, repair, supervision, recruitment, training, expediting, inspection, accounting, insurance, testing, protection, operation, use, management, retirement, reconstruction, maintenance, modification, relocation, or other work undertaken in accordance with Good Utility Practice or Applicable Requirements associated with any Capital Improvements, modifications, additions, or upgrades described in (ii) and (iii) herein.

EXHIBIT 6

EASEMENT

WHEN RECORDED MAIL TO:

SALT RIVER PROJECT
Land Department/PAB350
P. O. Box 52025
Phoenix, Arizona 85072-2025

**AFFIDAVIT EXEMPT PURSUANT TO
A.R.S. §§ 11-1134(A)(2) and (A)(3)**

**NON-EXCLUSIVE EASEMENT FOR INTERCONNECTION FACILITIES AND ACCESS
(HASSAYAMPA SWITCHYARD)**

Maricopa County
Parcel ## 141-21-004G

R/W# Agt.
Job #
W _____ C _____

THIS EASEMENT AGREEMENT ("**Easement Agreement**") is made as of the _____ day of _____, 201__, ("**Effective Date**") by Salt River Project Agricultural Improvement and Power District, an agricultural improvement district organized and existing under the laws of the State of Arizona ("**Grantor**") and Sun Streams 2, LLC, a Delaware limited liability company ("**Grantee**" or "**Interconnector**"). Except as otherwise defined in this Easement Agreement, all initial capitalized words shall have the meanings ascribed to them in the ICA (defined below).

RECITALS

A. Grantor together with Arizona Public Service Company, the City of Los Angeles by and through the Department of Water and Power, El Paso Electric Company, Public Service Company of New Mexico, Southern California Public Power Authority, and Southern California Edison Company is the owner of certain real property legally described on Exhibit "A" attached hereto, located in Maricopa County, Arizona (the "**Land**").

B. Grantor and Grantee are parties, along with Arizona Public Service Company, the City of Los Angeles by and through the Department of Water and Power, El Paso Electric Company, Public Service Company of New Mexico, Southern California Public Power Authority, and Southern California Edison Company, to that certain ANPP Hassayampa Switchyard Interconnection Agreement, dated _____ (together with all amendments thereto, the "**ICA**").

C. Pursuant to the ICA, Grantor, individually and on behalf of Arizona Public Service Company, the City of Los Angeles by and through the Department of Water and Power, El Paso Electric Company, Public Service Company of New Mexico, Southern California Public Power Authority, and Southern California Edison Company, shall grant Grantee a non-exclusive easement for the

purposes of locating the Interconnector's Interconnection Facilities, and installing, operating, maintaining, repairing and replacing Interconnector's Interconnection Facilities.

AGREEMENT

1. Grant of Easement. Grantor, individually and on behalf of Arizona Public Service Company, the City of Los Angeles by and through the Department of Water and Power, El Paso Electric Company, Public Service Company of New Mexico, Southern California Public Power Authority, and Southern California Edison Company, hereby grants to Grantee, its successors and assigns, the following easements (collectively, the "**Easement**");

(a) a non-exclusive easement on, over, and across the portion of the Land legally described on Exhibit "B" hereto (the "**Facilities Area**"), for the purpose of locating the Grantee's Interconnection Facilities, and installing, operating, maintaining, repairing and replacing the Interconnector's Interconnection Facilities; and

(b) a non-exclusive easement on, over, and across the portion of the Land legally described on Exhibit "C" hereto (the "**Access Area**," together with the Facilities Area, the "**Easement Area**"), for the purpose of providing pedestrian and vehicular access to the Facilities Area to exercise the rights granted to Grantee under item (a) above.

2. Condition of Easement. The Easement granted to Grantee hereunder is expressly made subject to:

(a) The condition and state of repair of the Easement Area as the same may be on the Effective Date; and

(b) All matters of record with respect to the Land as of the Effective Date.

3. Relocation. The Interconnector's Interconnection Facilities shall initially be constructed by Grantee within the Facilities Area, as designated or approved by Grantor and shall not be relocated or modified by Grantee without the consent of Grantor. The Grantee's Interconnection Facilities shall be relocated at the direction of Grantor when and as provided in Section 7.4, or any other applicable provision, of the ICA. Grantor may also relocate or modify the Access Area, provided that Grantee is afforded the same ability to access the Facilities Area as Grantee enjoyed prior to such relocation or modification. Subject to Grantor's right to require the relocations or modifications described in this paragraph 3, Grantor shall not grant rights to any other Hassayampa Interconnector to utilize the Easement Area in any manner which would materially interfere with the use thereof by Grantee pursuant to the Easement. Upon the relocation of the Grantee's Interconnection Facilities, or the relocation or modification of the Access Area, Grantor and Grantee shall execute, and cause the recordation of, an amendment to this Easement Agreement setting forth the new Easement Area resulting from such relocations or modification.

4. Term, Termination. The Easement and all rights and obligations provided herein shall expire automatically and without further act of any party upon termination of the ICA. At any time after such expiration, Grantor may request that Grantee execute, acknowledge and deliver to Grantor for recording, an instrument evidencing the termination of the Easement and all

rights and obligations hereunder, provided that Grantee agrees that such instrument is not required to effectuate the expiration.

5. Conflict with ICA. In the event of any conflict or inconsistency between the provisions of this Easement Agreement and those of the ICA, the terms and provisions of the ICA shall prevail.

6. Counterparts. This Easement Agreement may be executed in any number of counterparts with the same effect as if the parties had signed the same document. All counterparts shall be construed together and constitute one document.

IN WITNESS WHEREOF, the parties executed this instrument as of the day and year set forth above.

GRANTOR:

SALT RIVER PROJECT AGRICULTURAL IMPROVEMENT AND POWER DISTRICT an agricultural improvement district organized and existing under the laws of the State of Arizona

BY: _____
President / Vice President

David Rousseau / John R. Hoopes

ATTEST AND COUNTERSIGN:

Secretary / Assistant Secretary

John M. Felty / Lara F. Hobaica

STATE OF ARIZONA)
) ss.
County of Maricopa)

The foregoing instrument was acknowledged before me this _____ day of _____, 201_, by David Rousseau / John R. Hoopes as President/Vice President and John M. Felty / Lara F. Hobaica as Secretary/Assistant Secretary of **Salt River Project Agricultural Improvement and Power District**, on behalf of such district.

Notary Public

My Commission expires:

GRANTEE:

SUN STREAMS 2, LLC, a Delaware limited liability company

By: _____

Name: _____

Its: _____

State of _____)

County of _____)

On _____ before me, _____, Notary Public, personally appeared _____, who proved to me on the basis of satisfactory evidence to be the person(s) whose name(s) is/are subscribed to the within instrument and acknowledged to me that he/she/they executed the same in his/her/their authorized capacity(ies), and that by his/her/their signature(s) on the instrument the person(s), or the entity upon behalf of which the person(s) acted, executed the instrument.

I certify under PENALTY OF PERJURY under the laws of the State of _____ that the foregoing paragraph is true and correct.

WITNESS my hand and official seal.

Signature _____ (Seal)

EXHIBIT 7
INSURANCE

Project Insurance

1 Unless otherwise specified by the Administrative Committee for the ANPP Switchyard during the performance of Operating Work or Capital Improvements, the Operator shall procure and maintain in force, or cause to be procured and maintained in force, so as to be effective not later than the date on which the Operator shall first incur a risk of loss, damage or liability, insurance for the following casualty, automobile, property, and surety exposures.

1.1 Casualty Exposures.

1.1.1 Commercial General Liability insurance, with a combined single limit per occurrence for bodily injury and property damage not less than \$33 million. Policy extensions shall include coverage for:

Personal Injury

Explosion, Collapse and Underground (X.C.U.)

Broad Form Property Damage

Employees as Insureds

Blanket Contractual Liability

Owners and Contractors Protective Liability

Products and/or Completed Operations

Liability arising out of the ownership, maintenance or use of all vehicles, owned, non-owned or hired.

1.1.2 Professional Errors and Omissions Liability Insurance covering the Operator and the ANPP Switchyard Participants for liability only to direct or indirect purchasers of Interconnector's power arising out of or relating to the performance of Operating Work with deductibles or self-insured retentions and limits as determined solely by the ANPP Switchyard Participants after reasonable consultation with the Interconnector.

1.1.3 Automobile Liability insurance with an each occurrence limit of \$33 million.

1.1.4 Aircraft Liability Coverage for aircraft, owned, non-owned or hired in an amount not less than \$10 million, if applicable.

1.1.5 Worker's Compensation insurance with minimum statutory limits to cover obligations imposed by federal and state statutes having jurisdiction over the Operator's employees and Employer's Liability insurance with a minimum limit of \$1,000,000 per accident.

1.2 Property Exposures.

1.2.1 Unless otherwise directed by the Administrative Committee for the ANPP Switchyard at all times the Operator shall have and maintain in force and effect or cause to have and maintain in force and effect property insurance. Except as otherwise authorized herein or directed by the Administrative Committee for the ANPP Switchyard, such insurance shall be maintained for the insurable replacement cost, as the Administrative Committee for the ANPP Switchyard shall direct or in the absence of any such direction as the Operator may in its sole discretion determine, of all insurable property of the HAA and/or the JPP Interconnection Facilities as determined from time to time by independent qualified appraisers selected by the Operator.

1.2.2 In the event any Capital Improvements are undertaken the Operator shall procure and maintain, or cause to be procured and maintained, "All Risk" Builder's Risk property insurance.

1.3 Surety Exposures/Crime Insurance.

The standard form of Employees Dishonesty Bond or Crime Insurance, with limits of \$25 million covering loss of property of the HAA and/or the JPP Interconnection Facilities or funds of the ANPP Switchyard Participants and Hassayampa Interconnectors due to the dishonest or fraudulent acts committed by an officer or employee of the Operator and any ANPP Switchyard Participant, Hassayampa Interconnector, or contractor who is engaged in Operating Work or Capital Improvements.

Exhibit 8

Mitigation Facility Fee

Mitigation and Cost Allocation

For the purposes of this Exhibit 8, the term Arizona Nuclear Power Project High Voltage Switchyard ("ANPP HVS") shall mean a joint participation project comprised of two switchyards, the Palo Verde Switchyard and the HAA, including designated equipment within each yard and the string bus line # 2 between the two yards.

In order to maintain a 5% fault duty margin at ANPP HVS and to allow for future interconnections both at ANPP HVS and throughout neighboring systems, the installation of 12-ohm reactors was approved as mitigation, at a cost of \$13.37M ("Phase I Mitigation"). Of the 12 ohms of mitigation, 5 ohms were necessary to achieve 5% fault duty margin on the present day system. The remaining 7 ohms provide 3275 A of short circuit margin for the benefit of new generation and transmission interconnections to the ANPP HVS and neighboring systems. Accordingly, interconnectors at both the ANPP HVS and neighboring systems will be charged on a dollars per short circuit amp contribution basis (\$/A short circuit), based on the magnitude of the average contribution at both the Palo Verde Switchyard and the HAA. SRP, on behalf of the ANPP HVS, is working to identify and quantify each new source of fault current at the ANPP HVS to pursue appropriate reimbursement.

Cost per Amp Calculation

The cost analysis below for Phase I Mitigation results in \$2381 per short circuit amp contribution:

$$S.C. Cost Obligation = \$13.37M Total Cost * \frac{7 Ohm}{12 Ohm} * \frac{Average FCC}{3275 Amp Margin}$$

Average Fault Current Contribution (FCC)

The studies for fault current evaluate multiple types of faults and quantify the impact of each type. These types can include single phase to ground, two phase to ground and three phase faults. Because the ANPP HVS includes both the Palo Verde Switchyard and the HAA, the fault current at each switchyard is analyzed. The FCC that is used in the determination of the mitigation payment is the average of all the different types of faults at both switchyards.

$$\frac{FCC_{PV} + FCC_{HAA}}{N} = Average FCC$$

FCC_{PV} – Sum of ALL studied Palo Verde Fault Current Contributions

FCC_{HAA} – Sum of ALL studied Hassayampa Fault Current Contributions

N – Total number of studied Fault Current Contributions at both switchyards

The Average FCC is rounded up to the nearest amp.

The following is the Average Fault Current Contribution (FCC) from ANPP HVS Q21's Short Circuit Study Table 10.

$$\frac{(190A + 121A + 61A) + (587A + 379A + 132A)}{6} = 245A$$

The following is the Short Circuit Cost Obligation for ANPP HVS Q21.

$$\$583,345 = \$2,381 * 245A$$

For accounting purposes, this obligation will be divided between two invoices:

Invoice 1 - \$496,309.93

Invoice 2 - \$ 87,035.07

Operator will invoice Interconnector in accordance with Section 12.3.2 of this Agreement, but with payment due on or before the In-Service Date.

**Exhibit 9
Sun Streams 2
Interconnection Costs**

The Sun Streams Interconnection Facilities Study for Sun Streams Solar 2 Project (ANPP HVS Q21) at HAA, dated February 7, 2018 ("Facilities Study") sets forth a cost estimate for costs unique to the interconnection of Interconnector's Generating Facility ("Interconnection Costs".)

The Interconnection Costs does not include the costs associated with the Interconnector's Interconnection Facilities, nor the costs associated with JPP Interconnection Facilities, but rather assumes said interconnection facilities will be paid for and constructed by the SS1 Project owner prior to the In-Service Date. Based on this assumption, Interconnector agrees to pay the following incremental Interconnection Costs associated with interconnecting the Generating Facility:

Material & Labor (includes Participant Loading)	\$ 45,856
Contingency (20%)	\$ 9,173
Sub Total	\$ 55,038

Interconnector acknowledges and agrees that if the SS1 Project owner fully or partially abandons construction work of the JPP Interconnection Facilities, then Interconnector will enter into an agreement with Salt River Project as Operator of the HVS, and assume responsibility for all remaining unpaid costs associated with the completion of the construction of such facilities including but not limited to the remaining unpaid portion of the conceptual cost estimate, preliminary schedule, design and engineering requirements, construction issues, as well as any other assumptions and disclaimers identified in said Facilities Study associated with the engineering, procurement and construction of said JPP Interconnection Facilities.

Operator will invoice Interconnector for the Interconnection Costs in accordance with Section 12.3.2, but with payment due sixty (60) days prior to the In-Service Date.

Operator shall refund to Interconnector any amount by which the payment made by Interconnector for its estimated Interconnection Costs exceeds the actual costs within sixty (60) calendar days of the In-Service Date. Interconnector shall pay to Operator any amount by which the actual Interconnection Costs exceeds the payment made by Interconnector for the estimated Interconnection Costs, within sixty (60) calendar days of the In-Service Date.

Exhibit 9-1